



CFS Frame Lateral Design

*Jeff Ellis, P.E., S.E., SECB
Director of Codes & Compliance
Simpson Strong-Tie Company Inc.*

*NCSEA Webinar
August 10, 2017*



Presentation Overview

- Cold-Formed Steel (CFS) Codes & Standards
- CFS Framed Diaphragms
- CFS Framed Shear Walls
- CFS Diagonal Strap Braced Walls
- Design Examples



Research: CFS-NEES

National Science Foundation Funded Research:
NEESR-CR: Enabling Performance-Based Seismic
Design of Multi-Story Cold-Formed Steel Structures
(CFS-NEES)

Research Activities Summary

cold-formed steel
Frame FE

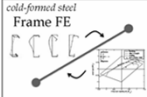

sub-structure
testing



high fidelity
FE

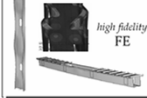

full-scale
shaking



www.ce.jhu.edu/cfsnees



PARAMETERS:

- 2-story rectangular building with design location in So. Calif.
- 23 ft x 50 ft x 9 ft story heights
- 600S162-54 and -43 studs at 16 inches on center at 1st and 2nd story, respectively, with bridging placed at mid-height
- 1200S200-54 and 97 at 24" on center roof and floor joists, respectively
- Roof and floor frame into ledger at top of wall
- Several phases with only structural sheathing and then finish materials subjected to Northridge Canoga Park and Rinaldi earthquake records

3



Research: CFS-NEES



4



Research: CFS-NEES

RESULTS:

100% Northridge Canoga Park Record
(PGA 0.354 g, 1.0 g 0.2 second Spectral Response Acceleration)

- **Phase 1** (only shear walls and diaphragms sheathed) peak story drift was 1.5% (9 ft height x 0.015 = 1.62")
- **Phase 2e** (all walls sheathed) peak story drift was 0.5% (9 ft height x 0.005 = 0.54")
- Some shear wall wood structural sheathing damage around fasteners and fastener tilt. Non-structural damage such as drywall cracking.

100% Northridge Rinaldi Record (video)
(PGA 1.1 g (was to be 0.83 g), 1.5g 0.2 second Spectral Response Acceleration):

- **Phase 2e** (all walls sheathed) Peak story drift was 1% (9 ft height x 0.01 = 1.08")
- Shear wall wood structural panel seam damage. Non-structural damage such as drywall cracking mainly at the openings.

** Some hold-downs in some of the shear walls were in tension at the same time versus our typical simplified component level assumptions of a compression-tension couple.*



5



Standards & References



- AISI S100 (S100-12) adopted by 2015 IBC
- AISI Standards (2012): *Including General Provisions, Floor & Roof System, Wall Stud Design, Header, Truss, & Prescriptive Methods, & Lateral (S213-07/S1-09(2012))*
- AISI CFS Design Manual (D100-13) [*Similar to AISC Steel Construction Manual*]
- AISI Design Guide (D110-16)
- Cold-Formed Steel Design, Fourth Edition
- SEAOC Structural/Seismic Design Manual – 2015 IBC

** CFS support online: www.steel.org, www.steel framing.org, www.cfsei.org, www.ccfsonline.org*

6



AISI S240-15 (2018 IBC)

AISI S240: North American Standard for Cold-Formed Steel Structural Framing

- Consolidates into single standard:
 - AISI S200: General Provisions
 - AISI S210: Floor and Roof System Design
 - AISI S211: Wall Stud Design
 - AISI S212: Header Design
 - AISI S213: Lateral Design
 - AISI S214: Truss Design



7



AISI S240-15

| | |
|-----------------|-----------------------------|
| A. General | ← AISI S200 |
| B. Design | ← AISI S211/211/212/213 |
| C. Installation | ← AISI S200/210/211/212/213 |
| D. QC/QA | ← New information |
| E. Trusses | ← AISI S214 |

8

|  AISI S240 – Chapter D | |
|-----------------------------------------------------------------------------------------------------------------------------------------------------------------|----------|
| D. QUALITY CONTROL AND QUALITY ASSURANCE | 5 |
| D1 General | 5 |
| D1.1 Scope and Limits of Applicability | 5 |
| D1.2 Responsibilities | 5 |
| D2 Quality Control Programs | 5 |
| D3 Quality Control Documents | 5 |
| D3.1 Documents to be Submitted | 5 |
| D3.2 Available Documents | 6 |
| D3.3 Document Retention | 6 |
| D4 Quality Assurance Agency Documents | 7 |
| D5 Inspection Personnel | 7 |
| D5.1 Quality Control Inspector Qualifications | 7 |
| D5.2 Quality Assurance Inspector Qualifications | 7 |
| D6 Inspection Tasks | 8 |
| D6.1 General | 8 |
| D6.2 Quality Control Inspection Tasks | 8 |
| D6.3 Quality Assurance Inspection Tasks | 8 |
| D6.4 Coordinated Inspection | 9 |
| D6.5 Conflicts | 9 |
| D6.6 Material Verification | 9 |
| D6.7 Inspection of Welding | 10 |
| D6.8 Inspection of Mechanical Fastening | 11 |
| D6.9 Inspection of Cold-Formed Steel Light-Frame Construction | 12 |
| D6.10 Additional Requirements for Lateral Force Resisting Systems | 12 |
| D7 Approved CFS Component Manufacturers and Installers | 14 |
| D8 Nonconforming Material and Workmanship | 14 |

9

|  AISI S400-15 (2018 IBC) | |
|------------------------------------------------------------------------------------------------------------------------------------------------------------------------------------------------------------------------------------------------------------------------------------------------------------------------------------------------------------------------------------------------------|---------------------------------------------------------------------------------------|
| <ul style="list-style-type: none"> • AISI S400: North American Standard for Seismic Design of Cold-Formed Steel Structural Systems • Consolidates into single standard: <ul style="list-style-type: none"> – AISI S110: Special Bolted Moment Frame – AISI S213: Lateral Design (<i>seismic provisions only</i>) |  |

10



AISI S400-15

Scope:

- This standard is applicable for the design and construction of cold-formed steel structural members and connections in seismic force-resisting systems and diaphragms in buildings and other structures.

Benefits:

- Streamline Review at BSSC, ASCE, ICC & NBCC
- Focus Subcommittee Expertise
 - Assign to Lateral Subcommittee
- Organize & Improve Existing Provisions
 - Combine CFSF SFRS & CFS-SBMF
 - Split WSP from Steel Sheet Sheathed Shear Walls
- Accommodate Future Growth – “Field of Dreams”
 - Ordinary vs. Special Shear Walls
 - New SFRS
 - Including Possible “Hybrid” Systems
 - Rocking & Self-Centering
 - Diaphragm Systems
 - Existing Building Requirements

11



AISI S400-15

- A. GENERAL**
- B. GENERAL DESIGN REQUIREMENTS**
- C. ANALYSIS**
- D. GENERAL MEMBER AND CONNECTION DESIGN REQ'TS**
- E. SEISMIC FORCE-RESISTING SYSTEMS**
- F. DIAPHRAGMS**
- G. QUALITY CONTROL AND QUALITY ASSURANCE**
- H. USE OF SUBSTITUTE COMPONENTS AND CONNECTIONS IN SEISMIC FORCE-RESISTING SYSTEMS**

APPENDIX 1: SEISMIC FORCE MODIFICATION FACTORS AND LIMITATIONS IN CANADA

12



AISI S400-15

E. SEISMIC FORCE-RESISTING SYSTEMS

- E1. CFS Light Frame Shear Walls Sheathed with Wood Structural Panels
- E2. CFS Light Frame Shear Walls with Steel Sheet Sheathing
- E3. CFS Light Frame Strap Braced Wall Systems
- E4 CFS Special Bolted Moment Frames (CFS–SBMF)
- E5. CFS Light Frame Shear Walls with Wood-Based Structural Panel Sheathing On One Side & Gypsum Board Panel Sheathing On the Other Side
- E6. CFS Light Frame Shear Walls with Gypsum Board or Fiberboard Panel Sheathing
- E7. Conventional Construction CFS Light Frame Strap Braced Wall Systems

13



Standards & References



CFSEI
COLD-FORMED STEEL
ENGINEERS INSTITUTE

TECHNICAL PUBLICATIONS (MO) | MEMBERSHIP | ENGINEER FINDER

Member Logout

MEMBERS ONLY HOME

ABOUT US

EDUCATION

COMMITTEES

MEDIA

LINKS

CALENDAR

TECHNICAL PUBLICATIONS

NOTE: All these publications are available for FREE DOWNLOAD in the Members Only Section.

Available technical documents:

- Free AISI Standards [click here](#) ←
- Construction Details [click here](#)
- Design Guides [click here](#)
- Issue Papers [click here](#)
- Research Reports [click here](#)
- Technical Notes [click here](#)

For all publications available for purchase [click here](#)



TECHNICAL NOTE \$5.00

On Cold-Formed Steel Construction

1201 15th Street, NW, Suite 310 Washington, DC 20005 (202) 785-2022

→ COLD-FORMED STEEL DESIGN SOFTWARE

Summary: This note gives basic information about computer programs available for the design of cold-formed steel framed buildings, structures, and structural elements. It is not necessarily a comprehensive list, but is based on the best available information to the CFSEI at the time of publication. It is not intended to endorse or exclude any particular

14

CFS Frame Lateral Design

7



CFS Member & Connection Design

AISI Manual: Cold-Formed Steel Design
2013 Edition, D100-13

**Similar to AISC Steel Const. Manual*

- Part I Dimensions and Properties
- Part II Beam Design
- Part III Column Design
- Part IV Connection Design
- Part V Supplementary Information
- Part VI Test Procedures

Note AISI test standards removed, but available online at www.aisistandards.org.



15



2015 IBC Section 2210



SECTION 2210
COLD-FORMED STEEL

2210.1 General. The design of cold-formed carbon and low-alloy steel structural members shall be in accordance with AISI S100. The design of cold-formed stainless-steel structural members shall be in accordance with ASCE 8. Cold-formed steel light-frame construction shall also comply with Section 2211. Where required, the seismic design of cold-formed steel structures shall be in accordance with the additional provisions of Section 2210.2.

2210.1.1 Steel decks. The design and construction of cold-formed steel decks shall be in accordance with this section.

2210.1.1.1 Noncomposite steel floor decks. Noncomposite steel floor decks shall be permitted to be designed and constructed in accordance with ANSI/SDI-NC1.0.

2210.1.1.2 Steel roof deck. Steel roof decks shall be permitted to be designed and constructed in accordance with ANSI/SDI-RD1.0.

2210.1.1.3 Composite slabs on steel decks. Composite slabs of concrete and steel deck shall be permitted to be designed and constructed in accordance with SDI-C.

2210.2 Seismic requirements for cold-formed steel structures. Where a response modification coefficient, *R*, in accordance with ASCE 7, Table 12.2-1, is used for the design of cold-formed steel structures, the structures shall be designed and detailed in accordance with the requirements of AISI S100, ASCE 8, or, for cold-formed steel special-bolted moment frames, AISI S110.

16



Cold-Formed Steel (CFS)

CFS is a steel shape formed after the steel has cooled and is fabricated from steel specified in AISI S100 (Specification)

NORTH AMERICAN SPECIFICATION FOR THE DESIGN OF COLD-FORMED STEEL STRUCTURAL MEMBERS

A. GENERAL PROVISIONS

A1 Scope, Applicability, and Definitions

A1.1 Scope

This *Specification* applies to the design of *structural members* cold-formed to shape from carbon or low-alloy steel sheet, strip, plate, or bar not more than 1 in. (25.4 mm) in *thickness* and used for *load-carrying* purposes in

- (a) Buildings, and
- (b) Structures other than buildings provided allowances are made for dynamic effects.

A2 Material

A2.1 Applicable Steels

This *Specification* requires the use of steels intended for structural applications as defined in general by the specifications of ASTM International listed in this section. The term *SS*

17



Cold-Formed Steel (CFS)

AISI S100 (AISI Specification)

A. General Provisions

1. Scope, material, loads, ASD, LRFD, limit states, strength increases from forming, and serviceability

B. Elements

1. Dimensional limits and effective widths

C. Members

1. Section properties, tension, flexural, compression, and combined loading

D. Structural Assemblies & Systems

1. Built-up, mixed, lateral & stability bracing, CFS light-frame construction, diaphragms, metal roofs and wall systems, standing seam roof panel systems, and roof system bracing & anchorage.

18



Cold-Formed Steel (CFS)

AISI S100 (AISI Specification)

E. Connections & Joints

1. General provisions, welds, bolts, screws, PAFs, rupture, connections to other materials.

F. Tests for Special Cases

1. Tests for determining structural performance, tests for confirming structural performance, and tests for determining mechanical properties

G. Design of CFS Structural Members & Connections for Cyclic Loading (Fatigue)

Appendix 1: Direct Strength Method
Appendix 2: Second-Order Analysis

Appendix A: Provisions Applicable to the U.S. & Mexico
Appendix B: Provisions Applicable to Canada

19



Cold-Formed Steel (CFS)

AISI S100 Section D4

D4 Cold-Formed Steel Light-Frame Construction

The design and installation of *structural members* utilized in cold-formed steel repetitive framing applications where the specified minimum base steel thickness is not greater than 0.1180 in. (2.997 mm) shall be in accordance with the AISI S200 and the following, as applicable:

- (a) Framing for floor and roof systems in buildings shall be designed in accordance with AISI S210, or solely in accordance with this *Specification*.
- (b) Wall studs shall be designed in accordance with AISI S211, or solely in accordance with this *Specification* either on the basis of an all-steel system in accordance with Section D4.1 or on the basis of sheathing braced design in accordance with an appropriate theory, tests, or *rational engineering analysis*. Both solid and perforated *webs* are permitted. Both ends of the stud shall be connected to restrain rotation about the longitudinal stud axis and horizontal displacement perpendicular to the stud axis.
- (c) Headers shall be designed in accordance with AISI S212, or solely in accordance with this *Specification*.
- (d) Light-framed *shear walls*, diagonal strap bracing (that is part of a structural wall) and *diaphragms* to resist wind, seismic and other in-plane lateral *loads* shall be designed in accordance with AISI S213.
- (e) Trusses shall be designed in accordance with AISI S214.

20



Cold-Formed Steel (CFS)

AISI S100-16 Section I4 * *CFSSF: Btwn. 18 mils (25 ga) to 118 mils (10 ga)*

I4 Cold-Formed Steel Light-Frame Construction

The design and installation of *structural members* utilized in cold-formed steel repetitive framing applications shall be in accordance with AISI S240 and, as applicable, the seismic requirements of AISI S400.

AISI S240-15 Commentary A2

In 2015, the provision that the Standard applies to applications where the specified minimum *base steel thickness* is not greater than 0.1180 inches (2.997 mm) was replaced with the provision that the Standard applies to *light-frame construction* applications, and a definition for the term *light-frame construction* was added to the Standard. *Cold-formed steel structural members for light-frame construction* applications are available in a variety of thicknesses. Standard thicknesses for *cold-formed steel structural members* are defined in AISI S201 (AISI, 2012c).

AISI S201-12 Section A1

A1 Scope

This standard provides criteria, including material and product requirements, for *structural members* and *nonstructural members* utilized in *cold-formed steel* framing applications where the specified minimum *base steel thickness* is between 18 mils (0.0179 inches) (0.455mm) and 118 mils (0.1180 inches) (2.997mm).



CFS Framing Types

Platform



Balloon



Ledger



Courtesy Dr. Schafer, Johns Hopkins 22



CFS Framing Types



Platform Framed



Platform Framed

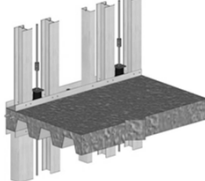

Platform Framed





Ledger Framed



23



CFS Framing Types

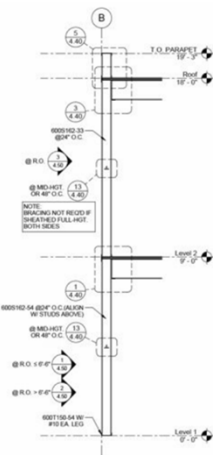

Wall Elevation and Ledger Framing Detail
(CFS-NEES Archetype Building)

Courtesy Dr. Schafer, Johns Hopkins

ENLARGED SECTION @ 2ND FLOOR - JOIST PERP.
1 1/2" = 1'-0"

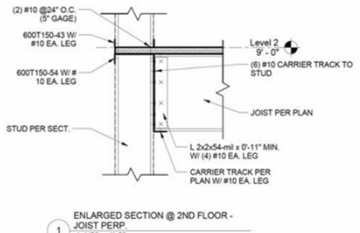

Level 2
9'-0"

(2) #10 @ 24" O.C. (5" GAGE)
600T150-43 W/ #10 EA. LEG

600T150-54 W/ #10 EA. LEG

STUD PER SECT.



Level 2
9'-0"

(6) #10 CARRIER TRACK TO STUD

JOIST PER PLAN

L 2x2x54-inl x 6'-11" MIN. W/ 45 #10 EA. LEG



CARRIER TRACK PER PLAN W/ #10 EA. LEG

24



CFS Framed Diaphragms

D. DIAPHRAGMS..... 21

- D1 General 21
 - D1.1 Seismic Requirements for Diaphragms 21
- D2 Diaphragm Design 21
 - D2.1 Available Shear Strength 21
 - D2.2 Wood Diaphragms 22
- D3 Special Seismic Requirements 23
 - D3.1 General 23
 - D3.2 Wood Diaphragms 23

25



CFS Framed Diaphragms

AISI S213 Section D2.1

Available shear strength:

Permitted to be calculated by principles of mechanics using values of fastener strength and sheathing shear resistance (B2)

OR

Tabulated values in Table D2-1 (Nominal Shear Strength) – CFSEI Tech Note 558b-1

Table D2-1
United States and Mexico
Nominal Shear Strength (R_n) for Diaphragms with Wood Sheathing^{1, 4}
(Pounds Per Foot)

| Membrane Material | Screw Size | Thick-ness (in.) | Blocked | | | | Unblocked | |
|---------------------------------------------------------------|------------|------------------|-----------------------------------------------------------------------------------|------|------|------|-------------------------------------------------------------------|--------------------------|
| | | | Screw spacing at diaphragm boundary edges and at all continuous panel edges (in.) | | | | Screws spaced maximum of 6" on all supported edges | |
| | | | 6 | 4 | 2.5 | 2 | Load perpendicular to unblocked edges and continuous panel joints | All other configurations |
| | | | Screw spacing at all other panel edges (in.) | | | | | |
| 6 | 6 | 4 | 3 | | | | | |
| Structural I | See note 2 | 3/8 | 768 | 1022 | 1660 | 2045 | 685 | 510 |
| | | 7/16 | 768 | 1127 | 1800 | 2255 | 755 | 565 |
| | | 15/32 | 925 | 1232 | 1970 | 2465 | 825 | 615 |
| C-D, C-C and other graded wood structural panels ³ | See note 2 | 3/8 | 690 | 920 | 1470 | 1840 | 615 | 460 |
| | | 7/16 | 760 | 1015 | 1620 | 2030 | 680 | 505 |
| | | 15/32 | 832 | 1110 | 1770 | 2215 | 740 | 555 |

26



CFS Framed Diaphragms

AISI S213 Sections D1 and D2 Requirements:



- **General:**
 - Use minimum 33-mil (20 ga) thick framing
 - Use minimum #8 flat-head tapping screws
- **Blocked Diaphragm:**
 - Use minimum 1 1/2" x 33 mil (20 ga) strap blocking
 - Aspect Ratio (length / width) ≤ 4:1
- **Unblocked Diaphragm:**
 - Increase deflection by 2.5
 - Aspect Ratio (length / width) ≤ 3:1



CFS Framed Diaphragms

AISI S213 Section D3 Special Seismic Requirements (R>3):

- Minimum panel width not less than 24 in.
- Open front structures w/rigid wood diaphragms resulting in torsional force distribution:

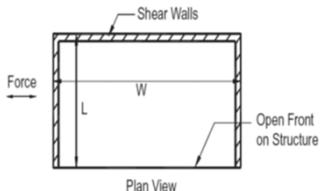

- Length normal to open side not greater than 25 ft and aspect ratio less than 1:1 for 1-story or 2:3 for greater than 1-story
- If calculations show diaphragm deflection can be tolerated, length normal to opening increased to (l/w) not greater than 3:2



CFS Framed Diaphragms - Deflection

$$\delta = \frac{0.052vL^3}{E_s A_c b} + \omega_1 \omega_2 \frac{vL}{\rho G t_{\text{sheathing}}} + \omega_1^{5/4} \omega_2 \left(\frac{v}{2\beta} \right)^2 + \frac{\sum_{i=1}^n \Delta_{ci} X_i}{2b} \quad (\text{Eq. D2.1-1})$$

where

| | |
|------------------------------------------------------------------------------------------------------------------------------------------------------------------------------------------------------------------------------------------------------------------------------------------------------------------------------------------------------------------------------------------------------------------------------------------------------------------------------------------------------------------------------------------------------------------------------------------------------------------------------------------------------------------------------------------------------------------------------------------------------------------------------------------------------------------------------------------------------------------------------------------------------------------------------------------------------------------------------------------------------------------------------------------------------------------------------------------------------------------------------------------------------------------------------------------------------------------------------------------------------------------------------------------------------------------------------------------------------------------------------------------------|----------------------------------------------------------------------------------------------------------------------------------------------------------------------------------------------------------------------------------------------------------------------------------------------------------------------------------------------------------------------------------------------------------------------------------------------------------------------------------------------------------------------------------------------------------------------------------------------------------------------------------------------------------------------------------------------------------------------------------------------------------------------------------------------------------------------------------------------------------------------------------------------------|
| <p>A_c = Gross cross-sectional area of <i>chord</i> member, in square inches (mm²)</p> <p>b = <i>Diaphragm</i> depth parallel to direction of load, in inches (mm)</p> <p>E_s = Modulus of elasticity of steel = 29,500,000 psi (203,000 MPa)</p> <p>G = Shear modulus of sheathing material, in pounds per square inch (MPa)</p> <p>L = <i>Diaphragm</i> length perpendicular to direction of load, in inches (mm)</p> <p>n = Number of <i>chord</i> splices in <i>diaphragm</i> (considering both <i>diaphragm chords</i>)</p> <p>s = Maximum fastener spacing at panel edges, in inches (mm)</p> <p>$t_{\text{sheathing}}$ = Nominal panel thickness, in inches (mm)</p> <p>t_{stud} = Nominal framing thickness, in inches (mm)</p> <p>v = Shear demand ($V/2b$), in pounds per linear inch (N/mm)</p> <p>V = Total lateral load applied to the <i>diaphragm</i>, in pounds (N)</p> <p>X_i = Distance between the "ith" <i>chord</i>-splice and the nearest support (braced w/line), in inches (mm)</p> <p>α = Ratio of the average load per fastener based on a non-uniform fastener pattern to the average load per fastener based on a uniform fastener pattern (= 1 for a</p> | <p>uniformly fastened <i>diaphragm</i>)</p> <p>β = 67.5 for plywood and 55 for OSB for U.S. Customary (lb/in^{1.5}) = 2.35 for plywood and 1.91 for OSB for SI units (N/mm^{1.5})</p> <p>δ = Calculated deflection, in inches (mm)</p> <p>Δ_{ci} = Deformation value associated with "ith" <i>chord</i> splice, in inches</p> <p>ρ = 1.85 for plywood and 1.05 for OSB</p> <p>ω_1 = $s/6$ (for s in inches) = $s/152.4$ (for s in mm)</p> <p>ω_2 = $0.033/t_{\text{stud}}$ (for t_{stud} in inches) = $0.838/t_{\text{stud}}$ (for t_{stud} in mm)</p> <p>For unblocked <i>diaphragms</i>, δ shall be multiplied by 2.50.</p> |
|------------------------------------------------------------------------------------------------------------------------------------------------------------------------------------------------------------------------------------------------------------------------------------------------------------------------------------------------------------------------------------------------------------------------------------------------------------------------------------------------------------------------------------------------------------------------------------------------------------------------------------------------------------------------------------------------------------------------------------------------------------------------------------------------------------------------------------------------------------------------------------------------------------------------------------------------------------------------------------------------------------------------------------------------------------------------------------------------------------------------------------------------------------------------------------------------------------------------------------------------------------------------------------------------------------------------------------------------------------------------------------------------|----------------------------------------------------------------------------------------------------------------------------------------------------------------------------------------------------------------------------------------------------------------------------------------------------------------------------------------------------------------------------------------------------------------------------------------------------------------------------------------------------------------------------------------------------------------------------------------------------------------------------------------------------------------------------------------------------------------------------------------------------------------------------------------------------------------------------------------------------------------------------------------------------|



Steel Deck References



2015 IBC

- § 2206 Composite Structural Steel & Concrete Structures
- § 2210.1.1.1 Non-composite Steel Floor Decks (SDI-NC1.0)
- § 2210.1.1.2 Steel Roof Decks (SDI-RD1.0)
- § 2210.1.1.3 Composite slabs on steel decks (SDI-C)

AISI S100-16 (2018 IBC 2210)

- S100 → S310-16 for steel deck diaphragm design
- S310 Table B1.1 Resistance & Safety Factors for Steel Deck Diaphragms

References:

- SDI DDM04 *SDI Diaphragm Design Manual (Coincides with AISI S310-16)*
- AISI S310 *Design of Profiled Steel Diap. Panels*

ASCE 7

- § 12.3.1 Diaphragm Flexibility

**SECTION 2206
COMPOSITE STRUCTURAL STEEL AND
CONCRETE STRUCTURES**

2206.1 General. Systems of structural steel elements acting compositely with reinforced concrete shall be designed in accordance with **AISC 360 and ACI 318**, excluding ACI 318 Chapter 14.

2206.2 Seismic design. Where required, the seismic design, fabrication and erection of composite steel and concrete systems shall be in accordance with Section 2206.2.1.

2206.2.1 Seismic requirements for composite structural steel and concrete construction. Where a response modification coefficient, R , in accordance with ASCE 7, Table 12.2-1, is used for the design of systems of structural steel acting compositely with reinforced concrete, the structures shall be designed and detailed in accordance with the requirements of **AISC 341**.

**AISI S310
Table B1.1
Safety Factors and Resistance Factors for Diaphragms**

| Load Type or Combinations Including | Connection Type | Limit State | | | | | |
|-------------------------------------|-----------------|--------------------|-----------------|----------------|------------------|-----------------|----------------|
| | | Connection-Related | | | Panel Buckling† | | |
| | | Ω_c (ASD) | ϕ_c (LRFD) | ϕ_c (LSD) | Ω_d (ASD) | ϕ_d (LRFD) | ϕ_d (LSD) |
| Wind | Welds | 2.15 | 0.75 | 0.60 | | | |
| | Screws | 2.00 | 0.80 | 0.75 | 2.00 | 0.80 | 0.75 |
| Earthquake and All Others | Welds | 3.00 | 0.55 | 0.40 | | | |
| | Screws | 2.30 | 0.70 | 0.55 | | | |

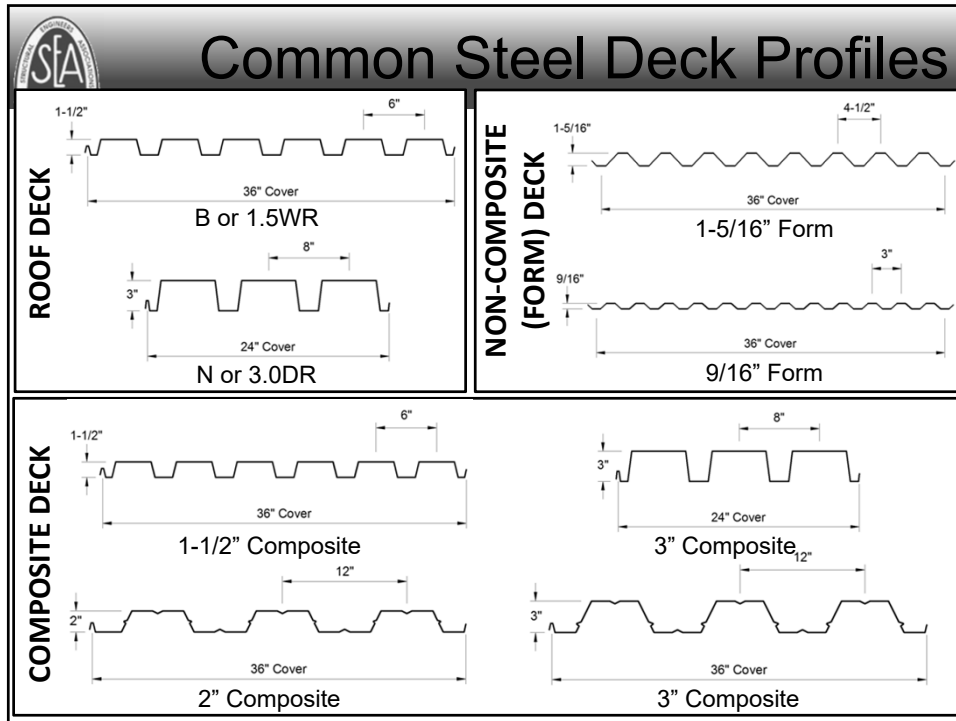

 **Common Steel Deck Attachments**

Sidelap - Deck Panel to Adjacent Panel

 **Arc Seam Weld (Top Seam Weld)**

 **Button Punch**

 **Proprietary Crimp**

 **Self-Drilling Tapping Screws**

 **Useful Reference Documents**

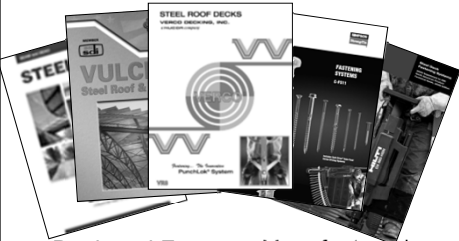
 **Deck and Fastener Manufacturer's Literature**

 **Evaluation Reports & FM Global Approvals**

 **Design Examples**

 **SDI Literature (www.sdi.org)**



Flexible Diaphragms (Seismic)

Diaphragms of wood panels or untopped steel decking permitted to be idealized as “flexible” for any of the following cases:

1. Where vertical elements are **concrete or masonry shear walls** or **steel braced frames** (ASCE 7-10 Section 12.3.1.1a)
2. **One and two-family dwellings** (ASCE 7-10 Section 12.3.1.1b)
3. Structures qualified under the **Simplified Procedure** (ASCE 7-10 Section 12.14.5)
4. In structures of **light-frame construction** where all of the following conditions are met (ASCE 7-10 Section 12.3.1.1c):
 - a. Non-structural toppings $\leq 1 \frac{1}{2}$ inches
 - b. Vertical elements of SFRS comply with drift limit
5. Where maximum **diaphragm deflection** $> 2 \times$ **Average Drift** of vertical elements (ASCE 7-10 Section 12.3.1.3)



CFS Framed Diaphragms

Shear Transfer:

- Shear transfer from diaphragms to wall top plate(s) or collector elements typically detailed with **blocking** between joists / rafters / trusses or with framing member if the framing is parallel to the wall.
- **Collector connection** required to be designed to resist **amplified seismic force** if $R > 3$ (AISI S213 Section C5.1.1.1)

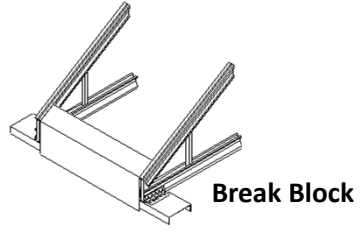

Break Block

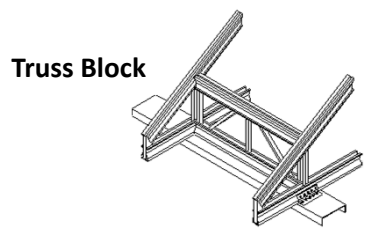

Truss Block



Collectors

ASCE 7-10 Exception for Collectors

12.10.2.1 Collector Elements Requiring Load Combinations with Overstrength Factor for Seismic Design Categories C through F

In structures assigned to Seismic Design Category C, D, E, or F, collector elements (see Fig. 12.10-1) and their connections including connections to vertical elements shall be designed to resist the maximum of the following:

1. Forces calculated using the seismic load effects including overstrength factor of Section 12.4.3 with seismic forces determined by the Equivalent Lateral Force procedure of Section 12.8 or the Modal Response Spectrum Analysis procedure of Section 12.9.
2. Forces calculated using the seismic load effects including overstrength factor of Section 12.4.3 with seismic forces determined by Equation 12.10-1.
3. Forces calculated using the load combinations of Section 12.4.2.3 with seismic forces determined by Equation 12.10-2.

Transfer forces as described in Section 12.10.1.1 shall be considered.

EXCEPTIONS:

1. The forces calculated above need not exceed those calculated using the load combinations of Section 12.4.2.3 with seismic forces determined by Equation 12.10-3.
2. In structures or portions thereof braced entirely by light-frame shear walls, collector elements and their connections including connections to vertical elements need only be designed to resist forces using the load combinations of Section 12.4.2.3 with seismic forces determined in accordance with Section 12.10.1.1.

37



Collectors

AISI S213 Section C5.2.1: Connections

C5 Special Seismic Requirements

Where required by Section C1 of this standard, the requirements of this section shall apply in addition to the requirements of Sections C2, C3 and C4.

C5.1 Shear Walls

Where steel or wood sheathing is provided for lateral resistance, the requirements of this section shall apply.

C5.1.1 Connections

C5.1.1.1: The available strength [factored resistance] of connections for top chord splices, *boundary members* and *collectors* shall exceed the following, as applicable:

- (a) *In the United States and Mexico:* Nominal tensile strength of the member, but need not exceed the amplified seismic load.
- (b) *In Canada:* Loads the system can deliver (C5.1.4), but need not exceed the maximum anticipated seismic loads calculated with $R_d R_o = 1.0$.

C5.1.1.2: The pull-out resistance of screws shall not be used to resist seismic forces.

38



CFS Framed (CFSF) Shear Walls

Hold-down System:

Continuous Rod Tie-Down System

1. Uplift (Tension):
Continuous steel rods and bearing plates
2. Compression:
Chord Pack – CFS studs each side of steel rod
 - A. Compression on studs on end of wall that uplifts
 - B. Compression on studs on end of wall being pushed down

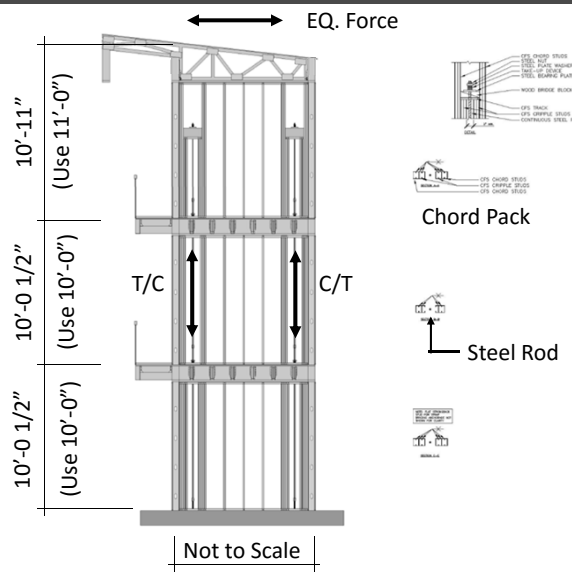

EQ. Force

Not to Scale

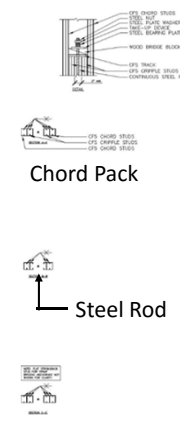

Chord Pack

Steel Rod

39



CFSF SW: Framing



SSMA Catalog

MEMBER DEPTH:
(Example: 6" = 600 × 1/100 inches)
All member depths are taken in 1/100 inches.
For all "T" sections member depth is the inside to inside dimension.

FLANGE WIDTH:
(Example: 1 3/8" = 1.625" = 162 × 1/100 inches)
All flange widths are taken in 1/100 inches.

600 S 162-54

STYLE:
(Example: Stud or Joist section = S)
The four alpha characters utilized by the designator system are:
S = Stud or Joist Sections
T = Track Sections
U = Channel Sections
F = Furring Channel Sections

MATERIAL THICKNESS:
(Example: 0.054 in. = 54 mils;
1 mil = 1/1000 in.)
Material thickness is the minimum base metal thickness in mils. Minimum base metal thickness represents 95% of the design thickness.



SFIA Catalog



AISI Manual



AISI Product Data (S20140)



CFSF SW: Stud Bracing

Wall Stud Flange Bracing: Steel Based Design

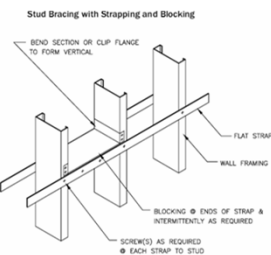

Strap & Blocking

BEND SECTION OR CLIP FLANGE TO FORM VERTICAL

FLAT STRAP

WALL FRAMING

BLOCKING @ ENDS OF STRAP & INTERMEDIATELY AS REQUIRED

SCREWS AS REQUIRED @ EACH STRAP TO STUD



Design Guide

2016 AISI Design Guide (D110-16)

Bracing Design Examples

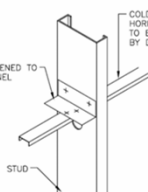

Channel & Clip Angle

COLD-ROLLED CHANNEL. HORIZONTAL BRIDGING TO BE SPACED AS REQ'D. BY DESIGN

CLIP ANGLE FASTENED TO STUD AND CHANNEL AS REQUIRED

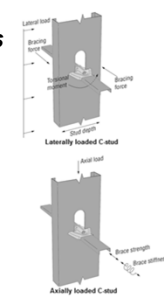

Proprietary Solutions

| Model No. | Stud Depth (in.) | Stud Thickness (in.) | Laterally Loaded C-Channel | | Axially Loaded C-Channel | | | |
|-----------|------------------|----------------------|------------------------------------|---------------------|------------------------------------|---------------------|-------|--------|
| | | | Allowable Braced Moment (in.-kips) | Brace Spacing (ft.) | Allowable Braced Moment (in.-kips) | Brace Spacing (ft.) | | |
| SUBH3.25 | 3.625 | 33 (20) | 345 | 230 | 370 | 1,450 | 1,380 | |
| | | 43 (18) | 355 | 430 | 250 | 420 | 2,780 | 4,850 |
| | | 54 (16) | 420 | 455 | 290 | 475 | 2,925 | 3,975 |
| | | 54 (16) | 500 | 800 | 435 | 630 | 3,440 | 4,675 |
| MSUBH3.25 | 3.625 | 68 (14) | 640 | 800 | 485 | 995 | 4,040 | 6,145 |
| | | 87 (12) | 675 | 860 | 515 | 770 | 6,860 | 14,705 |
| | | 33 (20) | 375 | 380 | 130 | 115 | 650 | 655 |
| SUBH3.25 | 6.000 | 43 (18) | 295 | 325 | 230 | 250 | 1,050 | 1,205 |
| | | 54 (16) | 355 | 500 | 275 | 415 | 1,130 | 1,770 |
| | | 54 (16) | 565 | 890 | 380 | 420 | 1,830 | 1,860 |
| | | 68 (14) | 655 | 925 | 455 | 620 | 1,860 | 2,855 |
| MSUBH3.25 | 6.000 | 87 (12) | 660 | 960 | 505 | 795 | 6,070 | 4,895 |
| | | 43 (18) | 255 | 370 | 190 | 160 | 505 | 535 |
| | | 33 (20) | 375 | 380 | 130 | 115 | 650 | 655 |



CFSF SW: Stud Bracing

Wall Stud Flange Bracing: Steel Based Design

Bridging Anchorage

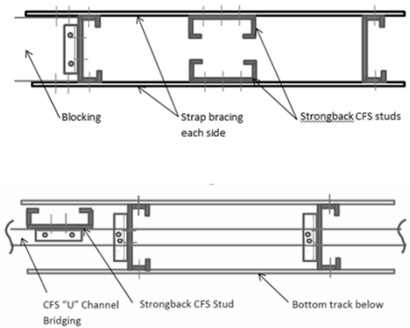

Blocking

Strap bracing each side

Strongback CFS studs

CFS "U" Channel Bridging

Strongback CFS Stud

Bottom track below

Design Example #4, CFSF Floor and Axial Load Bearing Stud Wall

Step 12 - Bridging Anchorage

From Step 11(c), the bridging must be anchored every 11 studs. See Figure 4-17 for a suggested anchorage detail using flat strap X-bracing.

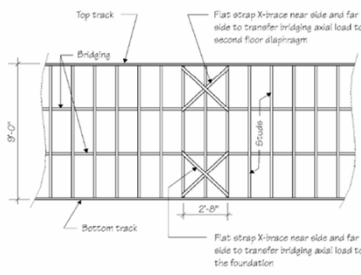

Top track

Flat strap X-brace near side and far side to transfer bridging axial load to second floor diaphragm

Bridging

Studs

Bottom track

Flat strap X-brace near side and far side to transfer bridging axial load to the foundation

AISI S110 Figure 42



CFSF SW: Stud Bracing

Wall Stud Flange Bracing: Steel Based Design

2015 IBC Section 2211.4 Permits use of either AISI S211 or S100

2211.4 Structural wall stud design. Structural wall studs shall be designed in accordance with either AISI S211 or AISI S100.

AISI S100

D3.3 Bracing of Axially Loaded Compression Members

To provide an adequate intermediate brace (or braces) that will allow an individual concentrically loaded compression member to develop its *required axial strength* [compressive axial force due to *factored loads*], the *required strength* [brace force due to *factored loads*] acting on the brace (or braces) shall be calculated in accordance with Eq. D3.3-1.

$$P_{tb} = 0.01 P_{ra} \tag{Eq. D3.3-1}$$

where

P_{tb} = *Required brace strength* [brace force due to *factored loads*] to brace a single compression member with an axial load P_{ra}

P_{ra} = *Required compressive axial strength* [compressive axial force due to *factored loads*] of individual concentrically loaded compression member to be braced, which is calculated in accordance with *ASD, LRFD, or LSD load combinations* depending on the design method used

The *stiffness of each brace* shall equal or exceed β_{tb} , as calculated in Eq. D3.3-2:

For ASD

$$\beta_{tb} = \frac{2[4 - (2/n)]}{L_b} (\Omega P_{ra}) \tag{Eq. D3.3-2a}$$

$\Omega = 2.00$

43



CFSF SW: Stud Bracing

Wall Stud Flange Bracing: Steel Based Design

AISI S211-07/S1-12 (Wall Stud Standard)

B3.1: Intermediate Brace Design

- For axial loaded members, each intermediate brace shall be designed for 2% of the design compression load in the member.
- For combined bending and axial loads, each intermediate brace shall be designed for the combined brace force determined by D3.2.1 (*correction to S211*) of S100 and 2% of design compression load.
- Brace forces are additive.

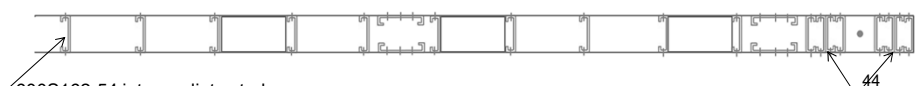

600S162-54 intermediate studs

(8) 600S162-54 chord studs



CFSF SW: Stud Bracing

AISI S211 Section B1(b): Sheathing Braced Design

When using sheathing braced design Section B1 of the Wall Stud Standard specifies:

1. Identical sheathing both sides or assumption of weaker sheathing both sides if not identical.
2. Engineering drawings must identify the sheathing as a structural element.
3. The wall stud shall be evaluated without the sheathing bracing for the LRFD load combination:

$$1.2D + (0.5L \text{ or } 0.2S) + 0.2W$$

45



CFSF SW: Stud Bracing

AISI S211 Section B1(b): Sheathing Based Design

Table B1-1 Maximum nominal stud axial load capacity limited by gypsum sheathing fastener connection (gypsum both sides).

Table B1-1
Maximum Axial Nominal Load [Specified Load]
Limited by Gypsum Sheathing-to-Wall Stud Connection Capacity

| Gypsum Sheathing | Screw Size | Maximum Nominal [Specified] Stud Axial Load |
|--------------------|------------|---------------------------------------------|
| 1/2 inch (12.7 mm) | No. 6 | 5.8 kips (25.8 kN) |
| 1/2 inch (12.7 mm) | No. 8 | 6.7 kips (29.8 kN) |
| 5/8 inch (15.9 mm) | No. 6 | 6.8 kips (30.2 kN) |
| 5/8 inch (15.9 mm) | No. 8 | 7.8 kips (34.7 kN) |

- Table values determined by tests. Factor of safety of 2 applied to determine allowable gypsum board load. Unbraced length taken as 2x fastener spacing

** Ex. used 600S162-54 x 8'-0" with 1/3 pt bracing nominal axial load is 13 kips*



46



CFSF SW: Sheathing

CFS framed shear wall sheathing

- Mechanical fasteners attaching sheathing to framing members. Sheathing types:
 - Wood structural panel (WSP) [R = 6.5]
 - Steel sheet [R = 6.5]
 - Gypsum [R = 2.0, SDC A-D, Max. A.R. 2:1]
 - Fiberboard [R = 2.0, SDC A-D, Max. A.R. 1:1]

47



CFSF SW: Fasteners

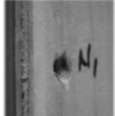

Test 40C
(4x8 CSP 2'x12')

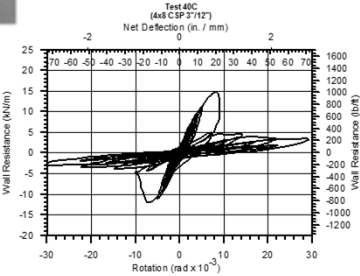

≈ 50% of sheathing screws overdriven



Test 40A
(4x8 CSP 2'x12')

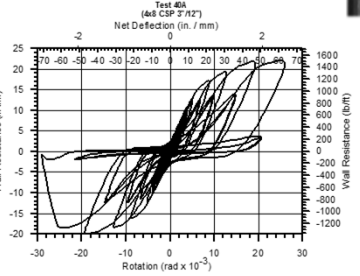

100% sheathing screws flush

Effect of overdriving sheathing fasteners (3/8 in. plywood)

Courtesy C.A. Rogers, McGill University, Montréal

48



CFSF SW: Fasteners

Drill Flute
The flutes allow drilled material to exit the hole. Once the flutes become completely embedded in the material, they can no longer remove the chips cut from the work material. Since these chips contain approximately 80% of the heat created by the drilling process, this can cause the point to over-heat and fail.

Point Length
The length of the drill point determines the material thickness which the screw can reliably penetrate. The unthreaded portion of the point, known as the pilot section, must be long enough to completely drill through the material before the threads engage. Since the threads advance faster than the drilling process, if they engage before drilling is done the fastener can bind and break.

Fastening Thicker Material to Metal
When fastening thicker materials, such as wood, to metal it is necessary to use a fastener with "wings" on the shaft or a pilot point. These fasteners are designed to prevent separation of the fastened material from the base metal, a condition known as "jacking." Once the wings contact the metal they break away before the threads engage.

Optimal Cutting Parameters by Screw Size

| Screw Size | Major Ø (in.) | RPM* | Applied Force* (lbs) | Work Material Hardness* |
|------------|---------------|------|----------------------|-----------------------------|
| #6 | 0.138 | 2200 | 80 | 20 Rockwell "C" Scale |
| #8 | 0.164 | 1900 | 95 | |
| #10 | 0.190 | 1600 | 105 | |
| #12 | 0.216 | 1400 | 115 | |
| #14 | 0.250 | 1200 | 130 | |
| #16 | 0.313 | 1000 | 160 | |

* Suggested maximum values. Stated speeds may require a variable-speed screwdriver motor and a partial trigger-pull. Harder material may require slower speeds and less applied force.

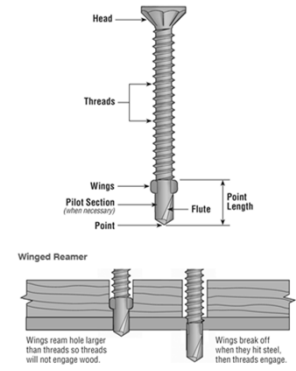

49



CFSF SW: Fasteners

Full-scale wood sheathed CFS framed shear wall tests comparing assemblies

- 2 in. and 6 in. on center panel edge fastener spacing
- Winged versus non-winged tipped self-tapping screws
- 20% design shear strength reduction





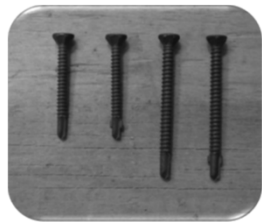

50



CFSF SW: Fasteners

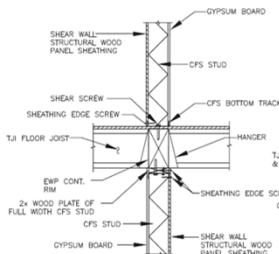

SECTION

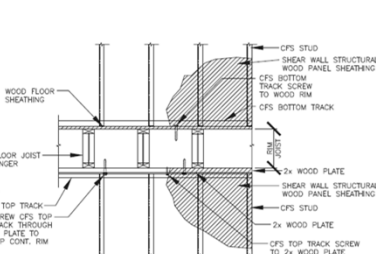

ELEVATION

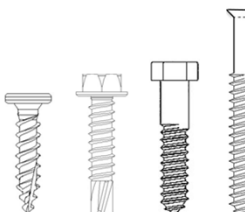

Screw attaching CFS track through wood sheathing into wood rim joist:

- Pre-drill track and use wood screw or lag screw
- NDS values do not apply to self-drilling tapping screw as drill tip removes more material and will lead to additional movement than typical wood screw or lag screw





CFSF SW: Fasteners

 **CFSF SW: OT Restraint**

CFS Construction Tie-down Systems

Conventional Hold-downs

53

 **CFSF SW: OT Restraint**

CFS Midrise Tie-down Systems – Significant OT Loads



Miracle Mile L.A.
CFS Midrise on Conc. ~~F~~odium
Courtesy of Dale Christian SE



CFSF SW: OT Restraint

CFS Construction Tie-down Systems

Continuous Rod Tie-Down Systems



- High Capacity
- Concentric
- Typically used for 3-stories and taller

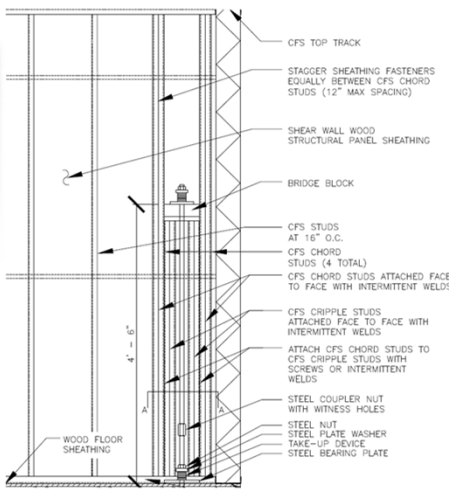

- CFS TOP TRACK
- STAGGER SHEATHING FASTENERS EQUALLY BETWEEN CFS CHORD STUDS (12" MAX SPACING)
- SHEAR WALL WOOD STRUCTURAL PANEL SHEATHING
- BRIDGE BLOCK
- CFS STUDS AT 18" O.C.
- CFS CHORD STUDS (4 TOTAL)
- CFS CHORD STUDS ATTACHED FACE TO FACE WITH INTERMITTENT WELDS
- CFS CRIPPLE STUDS ATTACHED FACE TO FACE WITH INTERMITTENT WELDS
- ATTACH CFS CHORD STUDS TO CFS CRIPPLE STUDS WITH SCREWS OR INTERMITTENT WELDS
- STEEL COUPLER NUT WITH WITNESS HOLES
- STEEL NUT
- STEEL PLATE WASHER TAKE-UP DEVICE
- STEEL BEARING PLATE
- WOOD FLOOR SHEATHING



SW Dsn. Ex.: OT Restraint (T)

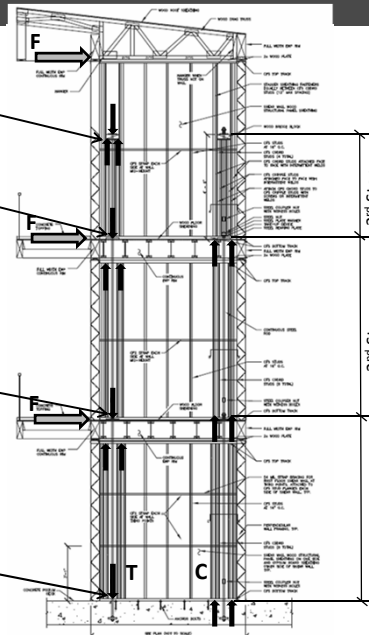

- 3rd story OT restraint Bridge Block Assembly to Rod
- 2nd story OT restraint Bearing Plate to Rod
- 1st story OT restraint Bearing Plate to Rod
- OT Restraint System Anchorage

Continuous Rod Tie-Down System Load Path

3rd Story Rod Length

2nd Story Rod Length

1st Story Rod Length

56



SW Dsn. Ex.: Chord Studs & OT Res.



AISI S213 Section C5.1.2.2 “Chord Studs” (vertical boundary members)

AISI S213 requires that the shear-wall CFS chord studs (vertical boundary members) and the uplift anchorage have the nominal strength to resist the lesser of 1) the load that the system can deliver and 2) the amplified seismic load. For ease of reference in this design example, the term “amplified seismic load” will mean the lesser of

1. The load the system can deliver and
2. The load determined from the ASCE 7 seismic load combinations with the overstrength factor Ω_o .

Since the floors and roof diaphragms are considered to be flexible in this example, the overstrength factor, Ω_o is equal to 2.5 per ASCE 7 Table 12.2-1 footnote g.

57



SEAOC SSDM Vol. 2 Ex. 3

Three-Story Light-Frame Multi-family Building Design Using Cold-Formed Steel Wall Framing and Wood Floor and Roof Framing



<http://seaoc.org/bookstore>



SW Dsn. Ex.: Location & Dimensions

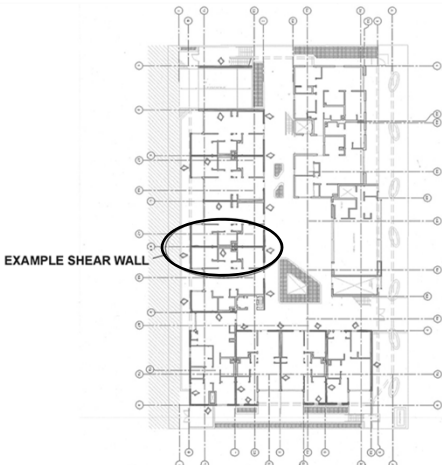

EXAMPLE SHEAR WALL

Building B

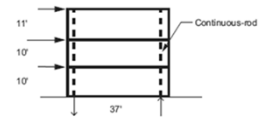

Figure 3-14. Option 1: Full-length, stacked shear wall

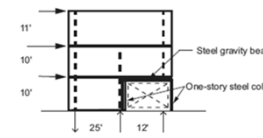

Figure 3-15. Option 2: Short first-floor shear wall

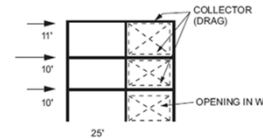



Figure 3-16. Option 3: Short, stacked shear wall



SW Dsn. Ex.: OT Restraint (T)

Continuous Rod Tie-Down Design – Steel Rod Selection

Table 3-35. Continuous rod tie-down system required, provided strength, and rod sizes (Option 3: Shear wall)—LRFD

| Level | Floor-to-Floor height (L) (ft) | Story-Level Amplified Seismic Uplift Force ¹ (P_{amp}) (lbs) | Rod Gross Area Required ² / Area Provided (A_g) for Strength (in ²) | Story-Level Seismic Uplift Force ² (P) (lbs) | Rod Net Tensile Area Required ³ / Area Provided (A_n) for Vertical Story Displacement ⁴ (in ²) | Rod Diameter Provided (in) (Rod tensile strength [ksi]) |
|-----------------------|--------------------------------|-----------------------------------------------------------------------------|------------------------------------------------------------------------------------------------|---------------------------------------------------------|--------------------------------------------------------------------------------------------------------------------------------------|---------------------------------------------------------|
| 3 rd Floor | 11 | 10,371 | 0.238 / 0.307 | 3305 | 0.063 / 0.226 | 5/8 (F_u = 58 ksi) |
| 2 nd Floor | 10 | 30,011 | 0.690 / 0.785 | 8604 | 0.150/ 0.606 | 1 (F_u = 58 ksi) |
| 2 nd Floor | 10 | 30,011 | 0.320 / 0.442 | 8604 | 0.150/ 0.334 | 3/4 (F_u =125 ksi) |
| 1 st Floor | 10 | 56,251 | 0.600 / 0.785 | 16,542 | 0.288/ 0.606 | 1 (F_u =125 ksi) |

- Continuous rod tie-down systems designed for strength, but also designed to ensure code drift compliance
- ICC-ES AC316 requires 0.20" total vertical displacement between restraints (includes rod elongation and take-up device deflection)
- Steel rod selection governed by strength in this example



1. Story-Level Amplified Seismic Uplift Force is from Table 3-34a.
2. Story-Level Seismic Uplift Force is from Table 3-34b.
3. Rod material: ASTM A36 $F_y = 36$ ksi, $F_u = 58$ ksi, $E = 29,000,000$
ASTM A193 B7 $F_y = 105$ ksi, $F_u = 125$ ksi, $E = 29,000,000$
4. Rod nominal strength (LRFD) = $0.75 F_u A_n A_{req} = P_{amp} / [(0.75 F_u)]$ from AISC 360 Equation J3-1, Table J.3.2 and corresponding commentary.
5. System vertical story displacement limit = $0.170 = 0.20$ inch – 0.030 inch take-up device initial seating. Δ_p , and design deflection, Δ_d , per manufacturer's evaluation report (ASD) $\times 1.4 = 0.170 \times 1.4 = 0.238$ inch (LRFD). System vertical story displacement limit = $\delta = 0.238$ inch = $PL/A_{req}E$ $A_{req} = PL/0.238 (E)$.
6. Rod net tensile area tabulated in 14th Edition of AISC *Steel Construction Manual* Table 7-17 or using the following equation: $A_n = 0.7854 \times (d - (0.9743/n))^2$





SW Dsn. Ex.: OT Restraint (T)

Tie-Down System Steel Bearing Plate Design & Detailing

- Multi-story CFS framed projects often use ledger framing
- Bearing plates designed to span stud gap
- Bearing plates should extend full width of stud and full length of stud pack. Coordination with panelizer important!
- Bearing plates often are 1 1/2" to 1 3/4" thick so track flanges need to be taller for screw to track connection
- Some use thicker studs to align floor-to-floor
- Bearing plate dapped into wood diaphragm requires shear transfer & plate might be thicker than sheathing





61



CFSF SW: Types

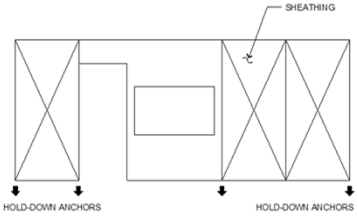
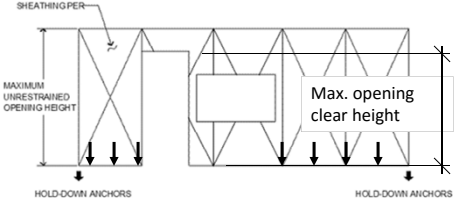



- **Type I Shear Wall**
Hold-downs at each end of each wall segment. Force transfer around openings.
- **Type II Shear Wall**
Hold-downs at ends of wall. Not designed for force transfer around openings.

62



CFSF SW: Requirements



AISI S213-07/S1-09 (2012)

Type I Limitations (C2.2):

1. Studs t min. 33-mils, 1 5/8 in. flange, 3 1/2 in. depth, 3/8 in. edge stiffener
2. Track min. of 33-mils, with 1 1/4 in. flange, 3 1/2 in. depth
3. Framing screws shall be #8 minimum compliant with ASTM C1513
4. Fasteners not less than 3/8 in. from panel edges
5. 12 in. min. wide panels. Perpendicular or parallel to framing
6. Maximum framing spacing of 24 in. o/c

63



CFSF SW: Requirements



AISI S213-07/S1-09 (2012)

Type I Limitations (C2.2) – continued :

7. Different thickness of track & stud than seismic table specifies not permitted unless noted as “(min.)”
8. Wall piers not less than 24 in. wide
9. Blocking required at panel joints (1 1/2 in. x 33-mil min. unless seismic table requires thicker)
10. Minimum #8 (head d > 0.285 in.) tapping screws or #10 (head d > 0.333”) tapping screws per table C2.1-3

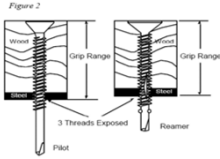

64



CFSF SW: Requirements

AISI S213-07/S1-09 (2012)

Type II Shear Wall Limitations (C3.1):

1. Full height wall segment with aspect ratio limit each end
2. SDC B – F, strength based on max screw spacing greater or equal to 4" o.c.
3. No OOP offsets
4. Collectors full length
5. Uniform top & bottom of wall elevations
6. Height not exceed 20 ft.

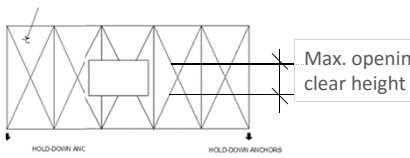

| Percent Full-Height Sheathing ^a | Maximum Opening Height Ratio ^b | | | | |
|--------------------------------------------|-------------------------------------------|------|------|------|------|
| | 1/3 | 1/2 | 2/3 | 5/6 | 1 |
| 10% | 1.00 | 0.69 | 0.53 | 0.43 | 0.36 |
| 20% | 1.00 | 0.71 | 0.56 | 0.45 | 0.38 |
| 30% | 1.00 | 0.74 | 0.59 | 0.49 | 0.42 |
| 40% | 1.00 | 0.77 | 0.63 | 0.53 | 0.45 |
| 50% | 1.00 | 0.80 | 0.67 | 0.57 | 0.50 |
| 60% | 1.00 | 0.83 | 0.71 | 0.63 | 0.56 |
| 70% | 1.00 | 0.87 | 0.77 | 0.69 | 0.63 |
| 80% | 1.00 | 0.91 | 0.83 | 0.77 | 0.71 |
| 90% | 1.00 | 0.95 | 0.91 | 0.87 | 0.83 |
| 100% | 1.00 | 1.00 | 1.00 | 1.00 | 1.00 |

Shear Resistance Adjustment Factor Table



CFSF SW: Requirements

ASCE 7 Seismic Load Combinations w/ Ω_0

Basic Combinations for Strength Design with Overstrength Factor (see Sections 2.3.2 and 2.2 for notation).

5. $(1.2 + 0.2S_{DS})D + \Omega_0 Q_E + L + 0.2S$
7. $(0.9 - 0.2S_{DS})D + \Omega_0 Q_E + 1.6H$

Basic Combinations for Allowable Stress Design with Overstrength Factor (see Sections 2.4.1 and 2.2 for notation).

5. $(1.0 + 0.14S_{DS})D + H + F + 0.7\Omega_0 Q_E$
6. $(1.0 + 0.105S_{DS})D + H + F + 0.525\Omega_0 Q_E + 0.75L + 0.75(L_r \text{ or } S \text{ or } R)$
8. $(0.6 - 0.14S_{DS})D + 0.7\Omega_0 Q_E + H$

Gross OT Moment = $\Omega_0 \times Q_E \times h$

Resisting Moment = $w_{DL} \times (b / 2)$

Ω_0 is applied only to the seismic load (Q_E) so dead load resisting moment contributes less to reducing uplift than in the seismic load combinations w/out Ω_0

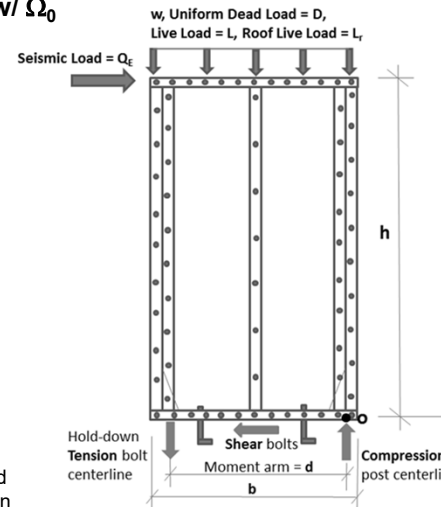

66



CFSF SW: Requirements

Dead Load Resisting Shear Wall Overturning

There are three methods designers use to determine the amount of dead load along the shear wall that can be used to counter the shear-wall uplift force.

1. Neglect the dead load for conditions when it is minimal (example: floor framing parallel to shear wall), which is the most conservative approach for the uplift side, but not the compression side of the shear wall.
2. Consider the shear wall as a rigid body where the dead load is used to resist the uplift and used as part of the gravity load demand in addition to the overturning compression load. Some justify this using a deep-beam analogy.
3. Consider the rim and top track as a beam on an elastic foundation. Such an analysis shows that typically only the dead load within a few stud bays can be mobilized to resist uplift. Further discussion can be found in FEMA 451 Chapter 10 as well as in the book *Structural Design of Low-Rise Buildings*, Section 6.7.

This design example uses the rigid body method although good arguments could be made in support of the “beam on elastic foundation” approach. Therefore, the dead load of and tributary to the wall is used to resist the uplift, and also it is used as part of the gravity-load demand to the chord-stud assembly on the compression side of the shear wall.

67



CFSF SW: Strength

AISI S213/S1-09 (2012)

Nominal Shear Strength Wind Load Table

- Monotonic tests
- S.F. = 2.0

Nominal Shear Strength Seismic Load Table

- Cyclic tests
- S.F. = 2.5

Table C2.1.1
United States and Mexico
Nominal Shear Strength (R_n) for Wind and Other In-Plane Loads for Shear Walls^{1,4,6,7,8}
(Pounds Per Foot)

| Assembly Description | Maximum Aspect Ratio (h/w) | Fastener Spacing at Panel Edges ² (Inches) | | | |
|-------------------------------------------------------------------------|----------------------------|-------------------------------------------------------|--------------------|-------------------|-------------------|
| | | 6 | 4 | 3 | 2 |
| 15/32" Structural 1 sheathing (4-ply), one side | 2:1 | 1065 ³ | - | - | - |
| 7/16" rated sheathing (OSB), one side | 2:1 | 910 ³ | 1410 | 1735 | 1910 |
| 7/16" rated sheathing (OSB), one side oriented perpendicular to framing | 2:1 | 1020 | - | - | - |
| 7/16" rated sheathing (OSB), one side | 2.1 ⁵ | - | 1025 | 1425 | 1825 |
| 0.018" steel sheet, one side | 2:1 | 485 | - | - | - |
| 0.027" steel sheet, one side | 4:1 | - | 1,000 ³ | 1085 ³ | 1170 ³ |
| | 2.1 ⁵ | 647 | 710 | 778 | 845 |

Table C2.1.3
United States and Mexico
Nominal Shear Strength (R_n) for Seismic and Other In-Plane Loads for Shear Walls^{1,4,7,8}
(Pounds Per Foot)

| Assembly Description | Max. Aspect Ratio (h/w) | Fastener Spacing at Panel Edges ² (Inches) | | | | Designation Thickness ^{5,6} of Stud, Track and Blocking (mils) | Required Sheathing Screw Size |
|-------------------------------------------------|-------------------------|-------------------------------------------------------|------|------|------|-------------------------------------------------------------------------|-------------------------------|
| | | 6 | 4 | 3 | 2 | | |
| 15/32" Structural 1 sheathing (4-ply), one side | 2:1 ¹ | 780 | 990 | - | - | 33 or 43 | 8 |
| | 2:1 | 890 | 1330 | 1775 | 2190 | 43 or 54 | 8 |
| 7/16" OSB, one side | 2:1 ¹ | 700 | 915 | - | - | 68 | 10 |
| | 2:1 ¹ | 825 | 1235 | 1545 | 2060 | 33 | 8 |
| | 2:1 | 940 | 1410 | 1760 | 2350 | 43 or 54 | 8 |
| | 2:1 | 1232 | 1848 | 2310 | 3080 | 54 | 8 |
| 0.018" steel sheet, one side | 2:1 | 390 | - | - | - | 68 | 10 |
| 0.027" steel sheet, one side | 4:1 | - | 1000 | 1085 | 1170 | 33 (min.) | 8 |
| | 2:1 ¹ | 647 | 710 | 778 | 845 | 33 (min.) | 8 |

68

CFS Frame Lateral Design

34



CFSF SW: Design Method

General Design Procedure:

1. Determine design loads (gravity, wind, seismic, lateral earth pressure, etc.)
2. Determine shear wall type/fasteners based on published shear wall shear strength determined using AISI S213.
3. Size boundary members and supporting elements of the structure.
4. Determine overturning and shear restraint required.
5. Check story drift and adjust design as required.
6. Design collector to shear wall connection
7. Select hold-down steel anchor rod material and diameter based on AISI S213 (*amplified seismic load < nominal strength for $R > 3$*) and design concrete anchorage per ACI 318 Chapter 17.

69



SW Dsn. Ex.: OT Anchorage (T)

Podium Connection (Tension Anchorage to Concrete)

LRFD Seismic Uplift Force = 16,542 lbs.
 Amplified Seismic Force = 56,215 lbs.

- Members supporting **discontinuous shear walls** are to comply with **ASCE 7 Section 12.3.3.3**.
 1. Connections of the discontinuous element be designed using the forces used to design it
 2. The member supporting the discontinuous element be designed using the load combinations including the overstrength factor, Ω_o
- **ASCE 7 Section 12.2.3.2** may be used for a flexible upper and rigid lower portion of the structure and the only anchorage load amplification would be the ratio of the R values (upper/lower).
- Steel anchor rod material and size determined using AISI S213, which requires chord studs and uplift anchorage have the nominal strength to resist the amplified seismic load.
- Then one designs the concrete anchorage based on ACI 318-11 Chapter 17.

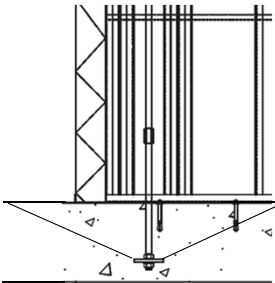

70



SW Dsn. Ex.: OT Anchorage (T)

Podium Connection (Tension Anchorage to Concrete)

ACI 318-14 Section 17.2.3 (SDC C – F)

Option 1: Design anchors so that a ductile steel anchor failure controls

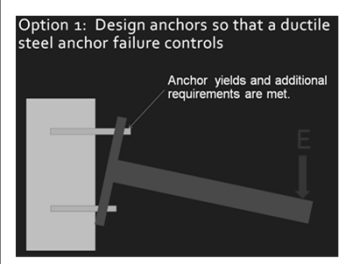

Anchor yields and additional requirements are met.

Option 2: Design anchors so that ductile yield controls in the attachment

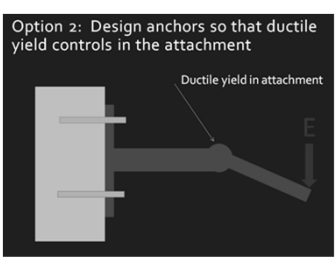

Ductile yield in attachment

Option 3: Design anchors for the max force that can be transmitted by a non-yielding attachment

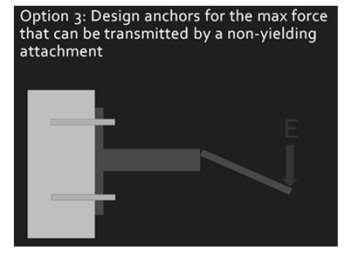

Option 4: Design the anchors for increased loads (provide overstrength)

• Scale up EQ loads by Ω_e

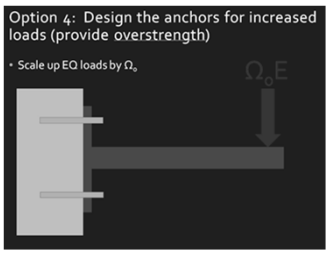

71



SW Dsn. Ex.: OT Anchorage (T)

Comparison of concrete tension anchorage for CFS framed shear walls using an $R \leq 3$ (SDC A to C and D in some cases) to those using an $R > 3$.

| Description | LRFD ¹ | Amplified LRFD ² | Amplified LRFD ³ |
|-----------------------------------------------------------------|------------------------------------------------------|------------------------------------------------------|--------------------------------------------------------------------------------------------------|
| Tension Load (P) | 16.542 kips | 56.251 kips | 56.251 kips |
| Steel Anchor Rod | 7/8" dia F1554 Gr36 (Fu=58 ksi) | 1" dia A93 B7 (Fu=125 ksi) | 1" dia A93 B7 (Fu=125 ksi) |
| Steel Plate Washer | 3/8"x2 1/4"x2 1/4" | 3/8"x2 1/2"x2 1/2" | 3/8"x2 1/2"x2 1/2" |
| Concrete Comp. Strength, f _c | 3000 psi | 3000 psi | 3000 psi |
| Concrete Depth | 12" | 22" | 22" |
| Steel Anchor Rod Embedment | 9.5" | 19" | 19" |
| Edge Distance | 14.5" | 24.5" | 27" |
| Steel Design Strength (ϕN_{sa}), (1.2*N _{sa}) | 20.1 kips, 32.2 kips | 56.8 kips, 90.9 kips | 56.8 kips, 90.9 kips |
| Concrete Design Strength (ϕN_{cb}), (N _{cb}) | 20.2 kips, 38.5 kips | 48.4 kips, 92.1 kips | 56.9 kips, 108.3 kips |
| ACI 318-14 17.2.3 Compliance | Section D.3.3.4.2(a) $N_{cb} > 1.2 \times N_{sa}$ | Section D.3.3.4.2(a) $N_{cb} > 1.2 \times N_{sa}$ | Section D.3.3.4.2(d) $P \times \Omega_o < \phi N_{sa}, \phi N_{cb}, \phi N_{pn}, \phi N_{sb}$ |

Notes:

- Steel anchor rod designed using LRFD for CFS framed shear walls using $R \leq 3$. Concrete designed to have its nominal strength greater than 1.2 times the nominal steel strength of the steel anchor rod.
- Steel anchor rod designed using the amplified seismic load for CFS framed shear walls using $R > 3$. Concrete designed to have its nominal strength greater than 1.2 times the nominal steel strength of the steel anchor rod.
- Steel anchor rod and concrete anchorage designed using the amplified seismic load for CFS framed shear walls using $R > 3$.



72

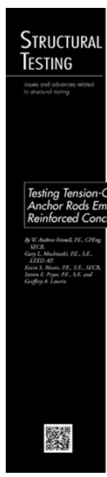

SW Dsn. Ex.: OT Anchorage (T)

Structure Magazine March 2014 Article: Testing Tension-Only Steel Anchor Rods Embedded in Reinforced Concrete Slabs

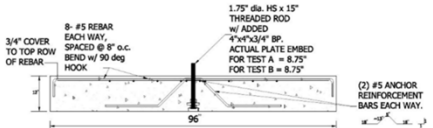
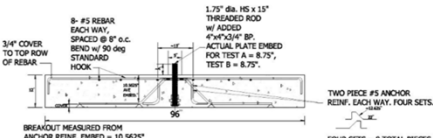

73



SW Dsn. Ex.: Chord Studs (C)

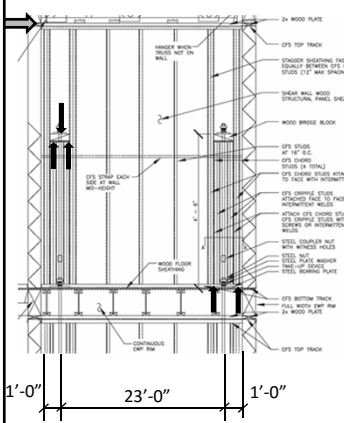

3rd Story Shear Wall

Chord Stud Assembly Compression Loads

The design forces shown are for the Option 3 shear wall (LRFD).

Roof-level Design Loads (third-floor shear walls)

Wall gravity-compression loads:

Dead load = 153 plf
 Live load = 0 plf (Roof live load not used in load combinations)
 Load combination = $(1.2 + 0.2(S_{DC})) D + 0.5 L$ ASCE 7 Eq 5 §12.4.3.2
 = $(1.2 + 0.2(1.117))(153) + 0.5 (0) = 218 \text{ plf}$
 Chord stud boundary gravity load = $(25\text{-ft-long wall}/2)(218 \text{ plf}) = 2725 \text{ lbs}$
 Assumed chord stud boundary width = 2 ft.

Wall seismic forces (amplified seismic loads – compression loads):

OTM (including the seismic overstrength factor Ω_n) = 270,848 ft-lbs
 Lever arm = centerline of hold-down to centerline of hold-down = $(25 \text{ ft} - 2(1 \text{ ft})) = 23 \text{ ft}$
 $C = T = 270,848/23 = 11,776 \text{ lbs}$.

Nominal shear-wall strength – compression loads:

Wall length = 25 ft, # 8 screws at 6 in o.c., $V_{nominal} = V_n = 890 \text{ plf}$
 OTM = $(25 \text{ ft})(890) (11 \text{ ft})/1000 = 244.75 \text{ ft-kips}$
 1.3 OTM = 318.175 ft-kips
 Lever arm = centerline of hold-down to centerline of hold-down = $(25 - 2(1 \text{ ft})) = 23 \text{ ft}$
 $C = 318.175/23 = 13,834 \text{ lbs} > 11,776 \text{ lbs}$; therefore, use 11,776 lbs.

74



SW Dsn. Ex.: Chord Studs (C)

Table 3-37. Option 3 shear wall: summary of CFS chord stud differential uplift and accumulative downward compression design loads

| Level | OTM Differential Uplift Loads (kips) | Load Type ¹ | OTM Compression Downward Loads (kips) | Load Type ² | Gravity Loads (kips) |
|-----------------------|--------------------------------------|------------------------|---------------------------------------|------------------------|----------------------|
| 3 rd Floor | 10.371 | amplified differential | 11.776 | amplified | 2.725 |
| 2 nd Floor | 19.640 | amplified differential | 35.679 | amplified | 13.938 |
| 1 st Floor | 26.240 | amplified differential | 66.180 | amplified | 25.138 |

1. The uplift loads are the amplified differential story loads from Table 3-36.
2. The downward compression design loads are the smaller of the calculated amplified and nominal loads.

⑤ Stud Bracing:
Example uses bracing mid-point at top 2 floors and third points at first floor.

Table 3-38. Option 3 shear wall: CFS chord stud size, number, and strength

| Level | Stud Height ¹ (ft) | Individual Chord Stud Size | Nominal Stud Strength ⁵ (kips) | Number of Chord Studs | Nominal Chord Assembly Axial Strength ⁶ (kips) | Amplified LRFD ² Axial Design Load (kips) | Chord Stud Assembly Width ⁴ |
|-----------------------|-------------------------------|----------------------------|-------------------------------------------|-----------------------|-----------------------------------------------------------|------------------------------------------------------|----------------------------------------|
| 3 rd Floor | 10 | 600S162-54(50) | 7.6 | 4 | 30.6 | 14.489 | (8 × 1.625 in) + 3 in = 16 in |
| 2 nd Floor | 9 | 600S162-54(50) | 8.8 | 6 | 52.9 | 49.617 | (6 × 1.625 in) + 9 in = 18.75 in |
| 1 st Floor | 9 | 600S162-54(50) | 11.8 | 8 | 94.7 | 91.318 | (8 × 1.625 in) + 9 in = 22 in |

75



SW Dsn. Ex.: Stud Bracing

Steel Stud Steel Bracing Systems

U-Channel bridging through stud web punchout attached to CFS stud with connector

- a. Requires coordination with building elements in stud bay
- b. Installs using one side of wall
- c. Does not bump out sheathing
- d. Bracing for axially loaded studs requires periodic anchorage to structure (e.g., strongbacks, diagonal strap bracing, etc.)
- e. Bracing of laterally loaded studs do not require periodic anchorage (system in equilibrium as torsion in stud resisted by U-channel bending)

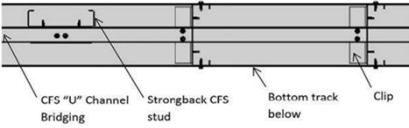

Figure 3-27. CFS stud-wall U-channel bridging—strongback anchorage (plan view)

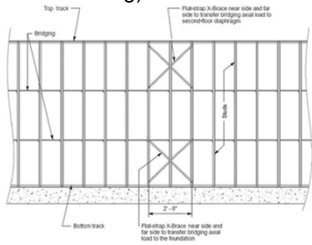



Figure 3-29. CFS stud-wall flat-strap bracing—diagonal strap bracing anchorage (elevation view)



SW Dsn. Ex.: Stud Bracing

Steel Stud Steel Bracing Systems

Flat strap bracing installed on each face of the CFS stud

- a. May be installed at other locations than stud punchout
- b. Required on both sides of wall
- c. Bumps out sheathing
- d. Bracing for axially loaded studs requires periodic anchorage to structure (e.g., strongbacks, diagonal strap bracing, etc.) (same load direction in stud flanges)
- e. Bracing for laterally loaded studs requires design of periodic blocking or periodic anchorage to structure (opposite load direction in stud flanges)

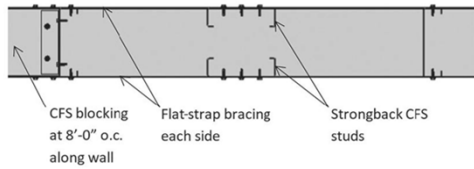
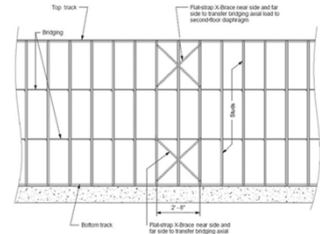



Figure 3-28. CFS stud-wall flat-strap bracing and blocking—strongback anchorage (plan view)

Figure 3-29. CFS stud-wall flat-strap bracing—diagonal strap bracing anchorage (elevation view)



SW Dsn. Ex.: Stud Bracing

Bracing for axially loaded compression studs

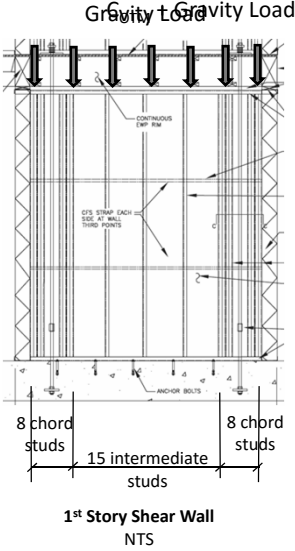

1st Story Shear Wall
NTS

Bracing for axially loaded compression studs

- IBC 2211.4 requires bracing design per AISI S100 or AISI S211
- S100 requires the brace strength to be 1% of axial load on stud and that it have a certain stiffness.
- S211 requires the brace strength to be 2% of axial load on stud. This example uses S211.
- Axial bracing force is cumulative; periodic anchorage required.

Two Axial Load Cases:

1. Bracing force from CFS compression chord studs with the amplified seismic load and the CFS intermediate studs for half the wall length with the LRFD gravity load.
2. Bracing force from all the studs with the LRFD gravity load along the entire wall length.



SW Dsn. Ex.: Deflection

Flexure + Shear + Non-linear Effects + Tie-down

$$\delta = \frac{2vh^3}{3E_s A_c b} + \omega_1 \omega_2 \frac{vh}{\rho G t_{\text{sheathing}}} + \omega_1^{5/4} \omega_2 \omega_3 \omega_4 \left(\frac{v}{\beta}\right)^2 + \frac{h}{b} \delta_v$$

Deflection of a blocked wood or sheet steel shear wall eq. variables:

- A_c = Cross sectional area of chord member
- b = Width of shear wall
- E_s = Modulus of elasticity of steel
- G = Shear modulus of sheathing material
- h = Wall height
- s = Maximum fastener spacing
- $t_{\text{sheathing}}$ = Panel thickness
- t_{stud} = Framing thickness
- v = Shear demand
- δ_v = Vertical deformation of anchorage/attachment details
- β = 67.5 Plywood, 55 OSB, and 41.67($t_{\text{sheathing}}/0.018$) sheet steel
- ρ = 1.85 Plywood, 1.05 OSB
- ω_1 = $s/6$
- ω_2 = $0.033/t_{\text{stud}}$
- ω_3 = $((h/b)/2)^{1/2}$
- ω_4 = 1 for wood sheathing, $(33/F_v)^{1/2}$

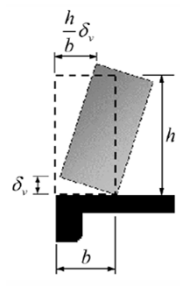

81



CFS Framed Shear Wall Drift Limits

ASCE 7-10 Seismic Story Drift Limitations:

Table 12.12-1 Allowable Story Drift, $\Delta_d^{a,b}$

| Structure | Risk Category | | |
|--------------------------------------------------------------------------------------------------------------------------------------------------------------------------------------------------------------------------------------------------|-----------------|---------------|---------------|
| | I or II | III | IV |
| Structures, other than masonry shear wall structures, 4 stories or less above the base as defined in Section 11.2, with interior walls, partitions, ceilings, and exterior wall systems that have been designed to accommodate the story drifts. | $0.025h_{sx}^c$ | $0.020h_{sx}$ | $0.015h_{sx}$ |
| Masonry cantilever shear wall structures ^d | $0.010h_{sx}$ | $0.010h_{sx}$ | $0.010h_{sx}$ |
| Other masonry shear wall structures | $0.007h_{sx}$ | $0.007h_{sx}$ | $0.007h_{sx}$ |
| All other structures | $0.020h_{sx}$ | $0.015h_{sx}$ | $0.010h_{sx}$ |

$\delta_x < 0.025H$

$\delta_x = C_d \delta_{xe} / I$

$0.025H = C_d \delta_{xe}$

For $R = 6.5$, $C_d = 4.0$

For 8 ft tall wall, drift limit is 0.60 in. (LRFD)



Diagonal Strap Braced Walls

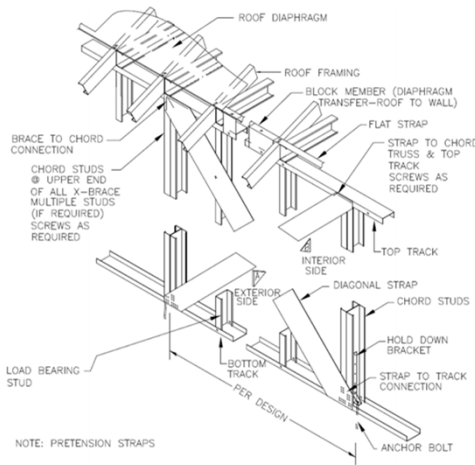

NOTE: PRETENSION STRAPS

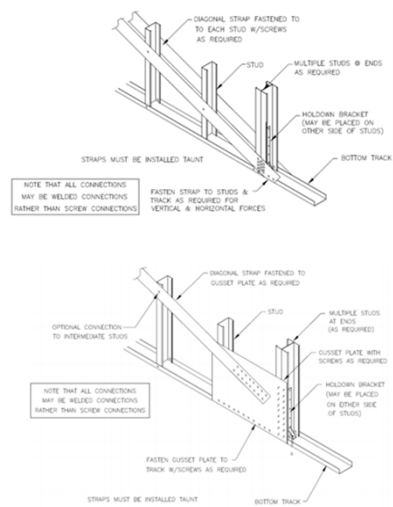



NOTE THAT ALL CONNECTIONS MAY BE WELDED CONNECTIONS RATHER THAN SCREW CONNECTIONS

STRAPS MUST BE INSTALLED TAUNT

Courtesy CFSEI



Diagonal Strap Braced Wall Testing

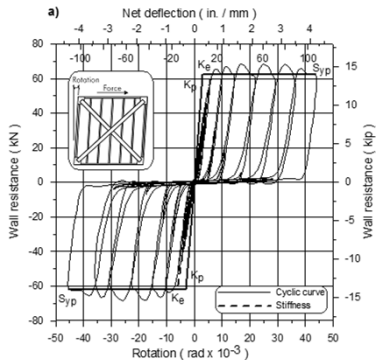

Inelastic behavior limited mainly to brace yielding.

Courtesy C.A. Rogers, McGill University, Montréal



Diagonal Strap Braced Wall Testing

S213 Section C5.2.1.3

Welds required for brace conn. unless:

- 1) Testing shows alternate connection provides for ductile behaviour or
- 2) $(R_t F_u) / (R_v F_y) \geq 1.2$ for bracing

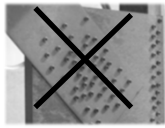

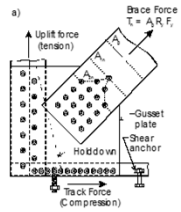

a)

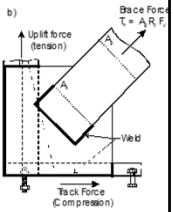



b)

S213 Section C5.2.2.2

Horizontal shear force resisted by:

- 1) Bottom track in compression
 - a) Using thicker track and/or blocking in track
- 2) Bottom track in tension
- 3) Device directly connected to brace and foundation

Compression failure of track

Unless sill bolt outside wall (track in tension)

Courtesy C.A. Rogers, McGill University, Montréal



Diagonal Strap Braced Wall Testing

S213 Section C4.1

Strap bracing with aspect ratio over 2:1 is not permitted unless chord stud analysis performed including consideration of joint flexibility and end moments

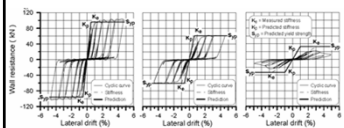
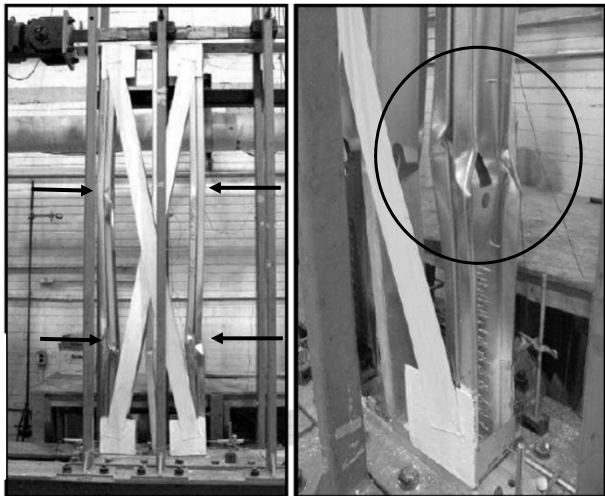



Figure C5-3 - Resistance versus Drift Hysteresis for 1:1, 2:1 and 3:1 Aspect Ratio Walls with Same Brace Size (Cameau and Rogers, 2008)



Photos courtesy of AISI & McGill University



Strap Braced Walls – A.R. – S400

Strap Braced Wall with A.R. > 1.9:1 – Structural analysis per software or per S400 Commentary E3.4.1

The structural analysis may be completed using analysis in software or in closed-form as presented here. Lateral load on a strap-braced *shear wall* is resisted by truss action (subscript T) and frame action (subscript F). The stiffness of each individually in resisting shear is:

$$k_T = \left[\frac{h^3}{b^2 E A_c} + \frac{(h^2 + b^2)^{1.5}}{b^2 E A_s} \right]^{-1}$$
(Eq. C-E3.4.1-1)

$$k_F = \left(\frac{6I_b + 4b}{I_c} + \frac{4b}{h} \times \frac{h^3}{24EI_c} \right)^{-1}$$
(Eq. C-E3.4.1-2)

where

k_T = Lateral stiffness of truss system

h = Height of wall

b = Width of wall

E = Modulus of elasticity of steel

A_c = Cross-sectional area of *chord stud*

A_s = Cross-sectional area of *strap*

k_F = Lateral stiffness of frame system

I_b = Moment of inertia of *track* about the axis of bending under frame action

I_c = Moment of inertia of *chord stud* about the axis of bending under frame action

For a shear force, V (developed from the expected strength of the *strap*), the deflection, δ , of the wall is:

$$\delta = \frac{V}{k_F + k_T}$$

(Eq. C-E3.4.1-3)

The amount of shear attributed to the frame action, V_F , is:

$$V_F = (k_F)\delta$$

(Eq. C-E3.4.1-4)

V_F results in a moment at the base of the *chord stud* (M_b) and a moment above the *hold-down* (M_h) due to frame action, which can be calculated by using Equations C-E3.4.1-5 and C-E3.4.1-6:

$$M_b = \frac{V_F h}{2} \left(\frac{3I_b h + 1}{I_c b} \right)$$

(Eq. C-E3.4.1-5)

$$M_h = M_b \left(\frac{M_b - h_0}{M_b} \right)$$

(Eq. C-E3.4.1-6)

where h_0 is the distance from the base to the top of the *hold-down*. The assumption, consistent with experimental observations, is that the *hold-down* stiffens the *chord stud* and the critical location for axial and bending demands is at the cross-section of the *chord stud* immediately adjacent to the end of the *hold-down*. As a result, the *Standard* requires that this location (M_b) be checked – this provides some relief from the large bending demands that are assumed from the assumption of full *joint* fixity.

The deflection calculated per Equation C-E3.4.1-3 is not intended to be an approximation of actual system deflection for the purposes of seismic design. The provisions for narrow strap-braced *shear walls* do not allow frame action to be considered in the *nominal strength [nominal resistance]*, but do require that frame action be considered to ensure the *desired energy-dissipating mechanism of strap yielding* is achieved.



Diagonal Strap Braced Walls

EARTHQUAKE ENGINEERING AND STRUCTURAL DYNAMICS, VOL. 25, 1373–1389 (1996)

SEISMIC IMPACT LOADING IN INELASTIC TENSION-ONLY CONCENTRICALLY BRACED STEEL FRAMES: MYTH OR REALITY?

ROBERT TREMBLAY* AND ANDRÉ FILIATRAULT†

Department of Civil Engineering, Ecole Polytechnique, University of Montreal Campus, P.O. Box 6079, Station "Centre-Ville", Montreal, Canada H3C 3A7

Tension-Only Centrically Braced Frames (TOCBF) exhibit deteriorating pinched hysteretic behaviour during strong earthquakes. Slender braces transit between an elastic buckling state, a restraightening state, in which they carry almost no load, an elastic tensile loading state as they are suddenly taut and, finally, a tensile yielding state. It has long been suspected that the sudden increase in tensile forces in the braces of TOCBF creates detrimental impact loading on the connections and other structural elements. No experimental evidence, however, has been provided so far to confirm, or to quantify, this impact phenomenon. This paper addresses this issue through shake table tests of half scale, two-storev.

CONCLUSION

(2) A simple equation, based on a combination of response spectrum and substitute structure techniques, has been proposed to estimate this increase in brace forces at the design stage. The predictions of this proposed equation correlates well with the shake table results obtained herein. Alternatively, a conservative dynamic amplification factor for the braces of 1-15 could be used for preliminary code design applications.



Diagonal Strap Braced Walls – S213

Table C5-1
R_y and R_t Values for Diagonal Strap Bracing Members

| Yield Strength | R _y | R _t |
|------------------|----------------|----------------|
| 33 ksi [230 MPa] | 1.5 | 1.2 |
| 37 ksi [255 MPa] | 1.4 | 1.1 |
| 40 ksi [275 MPa] | 1.3 | 1.1 |
| 50 ksi [340 MPa] | 1.1 | 1.1 |

C5 Special Seismic Requirements

C5.2 Diagonal Strap Bracing

In the absence of verified physical properties measured in accordance with an *approved* test method, the R_y and R_t values in Table C5-1 shall be used. In either case, R_y shall not be less than 1.1.

C5.2.1 Connections

C5.2.1.1: The *available strength [factored resistance]* of connections for diagonal strap bracing members, boundary members and collectors shall exceed the expected yield strength of the diagonal strap bracing member, A_gR_yF_y, except the *available strength [factored resistance]* need not exceed the following, as applicable:

(a) In the United States and Mexico: Amplified seismic load.

C5.2.2 Chord Studs and Anchorage

C5.2.2.2: All members in the load path and uplift and shear anchorage thereto from the diagonal strap bracing member to the foundation shall have the nominal strength to resist the expected yield strength, A_gR_yF_y, of the diagonal strap bracing member(s), except the *nominal strength* need not exceed the following, as applicable:

(a) In the United States and Mexico: Amplified seismic load.

Ratios of expected stress to specified minimum stress



Diagonal Strap Braced Walls – CFSEI



TECHNICAL NOTE \$5.00
On Cold-Formed Steel Construction

LBS 1500 Blaine, W. Suite 300 • Waukegan, IL 60085 • 815.760.0222

Design of Diagonal Strap Bracing Lateral Force Resisting Systems for the 2006 IBC

This Technical Note is an editorial revision of CFSEI Technical Note L601-09.
 Summary: This Technical Note is intended to discuss some of the design requirements, detailing and practical limitations of diagonal strap bracing design. Diagonal flat strap bracing is a commonly used type of lateral force resisting system in residential and low rise commercial cold-formed steel applications.
 Disclaimer: Design steel frames are not intended to preclude the use of other materials, assemblies, structures or designs when these other designs and materials demonstrate equivalent performance for the intended use. CFSEI documents are not intended to exclude the use and implementation of any other design or construction technique.

INTRODUCTION

Structures require a resisting system to transfer lateral loads imposed on them. Typically these loads are from wind or seismic forces. A commonly used type of lateral force resisting system in residential and low rise commercial cold-formed steel applications is diagonal flat strap bracing. When designing this type of force resisting system there are a number of design and serviceability considerations that should be investigated. These include loads, strap size, fastener quantity, connection detailing, and construction practices.

GENERAL BRACING REQUIREMENTS

The *International Building Code (IBC)* and the *Uniform Building Code (UBC)* contain limited information on requirements for designing diagonal strap bracing lateral force resisting systems. The designer is required to design diagonal straps and their connections in accordance with the design standard referenced in the model code. The 2006 IBC references the *North American Specification for the Design of Cold-Formed Steel Structural Members (ANSI NAS-01)*, including *2004 Supplement (ANSI NASPEC-SUP04)* and the 1997 IBC references the *ANSI Specification for Design of Cold-Formed Steel Structural Members, 1986 (with December 1989 Addendum)*. In the *ANSI Standard for Cold-Formed Steel Framing - Lateral Design (ANSI C145)* the design of diagonal strap bracing is to be done in accordance to the provisions of NAS-01.

TYPES OF DIAGONAL STRAP BRACING

Diagonal strap bracing can be detailed in a variety of different styles. Commonly diagonal strap bracing is used on the outside flange of perimeter load bearing studs (Figure 1). Another option is to use double sided diagonal strap bracing where there are straps on both the inside and outside flange of the studs. With either of these styles the strap may either be a wide strap connecting directly to the stud and track (Figure 2), or a narrower strap where a gusset plate is used to make the connection between the strap and the stud and track (Figure 3).

Wide straps that connect directly to the stud and track may be preferred over straps with gusset plates for a couple of reasons. First the gusset plates and associated fasteners add thickness to the wall which may be difficult to conceal with siding or exterior finish. Second, wider straps connecting directly to the stud and track will ultimately require fewer fasteners which will reduce installation time.

DESIGN EXAMPLE

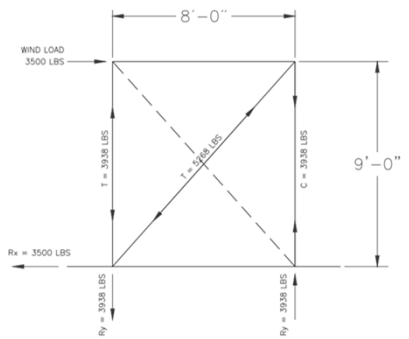

Following is a design example for diagonal strap bracing using gusset plates to resist wind loads. The dimensions and load are shown in the drawing below. The flanges of the wall studs are considered to be braced and gravity loads are ignored.

Cold-Formed Steel Engineers Institute 1 TECHNICAL NOTE L601-10 September 2010



Other CFS Lateral Systems

Table 12.2-1 (Continued)

| Seismic Force-Resisting System | ASCE 7 Section Where Detailing Requirements Are Specified | Response Modification Coefficient, R ^a | Overstrength Factor, Ω _s ^b | Deflection Amplification Factor, C _d ^b | Structural System Limitations Including Structural Height, h _s (ft) Limits ^c | | | | |
|----------------------------------------------------------------|-----------------------------------------------------------|---------------------------------------------------|--------------------------------------------------|--------------------------------------------------------------|----------------------------------------------------------------------------------------------------|----|----------------|----------------|----------------|
| | | | | | Seismic Design Category | | | | |
| | | | | | B | C | D ^d | E ^d | F ^e |
| C. MOMENT-RESISTING FRAME SYSTEMS | | | | | | | | | |
| 12. Cold-formed steel—special bolted moment frame ^f | 14.1 | 3½ | 3 ^g | 3½ | 35 | 35 | 35 | 35 | 35 |

CFS Moment Frames and Braced Frames in IBC

- 2012 IBC 2210.2 references **AISI S110** – “*Standard for Seismic Design of CFS Structural Systems – Special Bolted Moment Frames*”
 - CFS moment frames for 1-story structures (mezzanines and racks)
 - Ductility achieved through bolted connections
 - UFC 3-310-04 Table 2-1 lists R = 3.5, 1-story & 35 ft maximum height
- No CFS braced frames in IBC

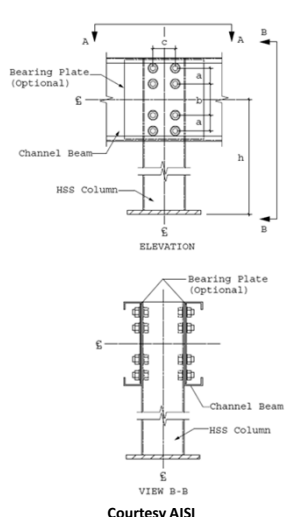

ELEVATION
VIEW B-B
Courtesy AISI



CFSEI Shear Wall Design Guide

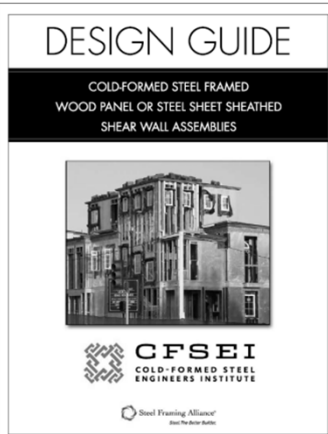

www.cfsei.org
 or
<https://shop.steel.org/c/50/manuals-and-design-guides>

|  CFSEI Shear Wall Design Guide Examples | |
|---------------------------------------------------------------------------------------------------------------------------------|-------------------------------------------------------------------------------------------------------------------------------|
| 2.0 Shear Wall Design Examples | |
| 2.1 | EXAMPLE 1 Wood sheathed cold-formed steel framed Type I shear wall resisting seismic (ASD)..... 16 |
| 2.2 | EXAMPLE 2 Steel sheet sheathed cold-formed steel framed Type I shear wall supported by a beam resisting seismic (ASD)..... 19 |
| 2.3 | EXAMPLE 3 Steel sheet sheathed cold-formed steel framed Type II shear wall resisting seismic (LRFD)..... 22 |
| 2.4 | EXAMPLE 4 Steel sheet sheathed cold-formed steel framed Type I shear wall resisting seismic (LRFD)..... 26 |
| 2.5 | EXAMPLE 5 Steel sheet sheathed cold-formed steel framed Type I shear wall resisting wind (LRFD) 29 |
| 3.0 Shear Wall Component and Story Drift Analysis | |
| 3.1 | Collector and Collector to Shear Wall Connection for Seismic - LRFD (EXAMPLE 4) 31 |
| 3.2 | Chord Studs, Overturning Restraint, and Shear Transfer - ASD (EXAMPLE 2)..... 39 |
| 3.3 | Chord Studs and Overturning Restraint - LRFD (EXAMPLE 3)..... 41 |
| 3.4 | Shear Wall Design Deflection - LRFD (EXAMPLE 4)..... 45 |

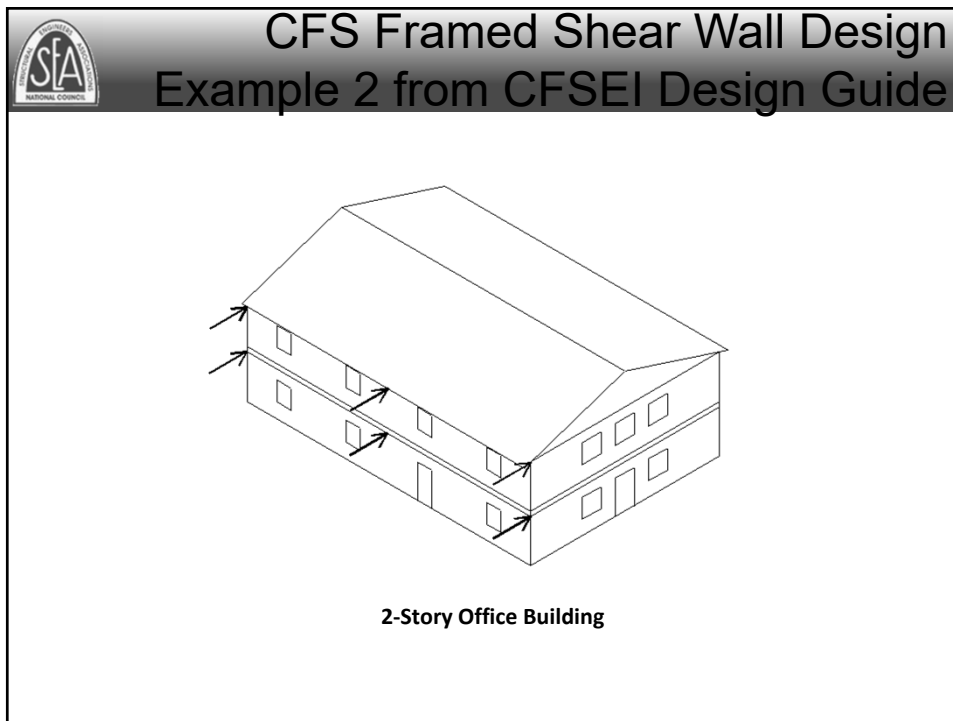

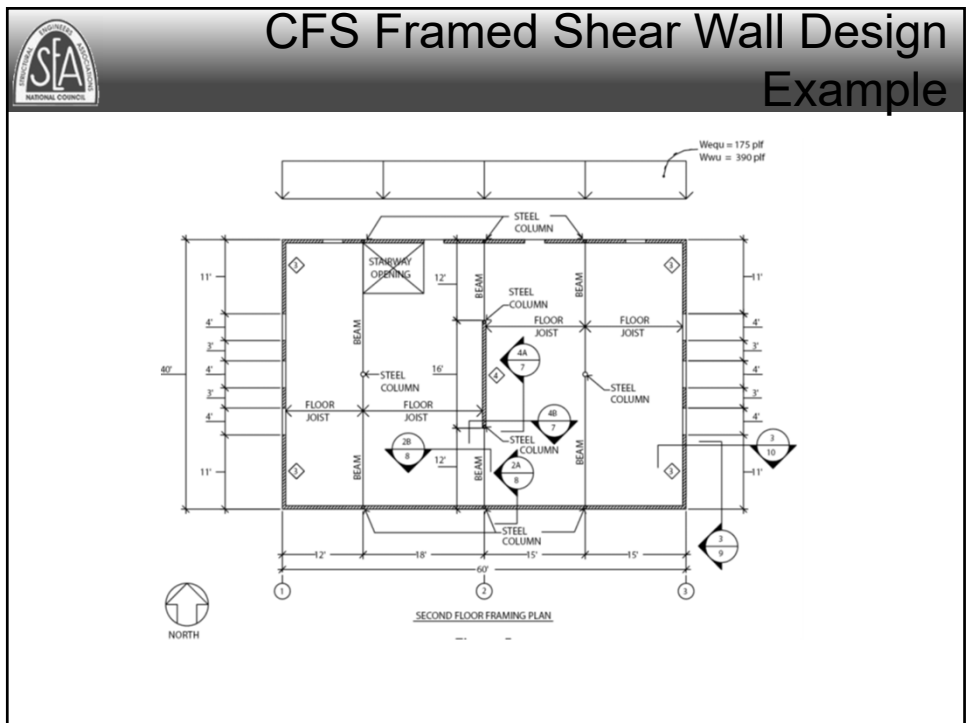
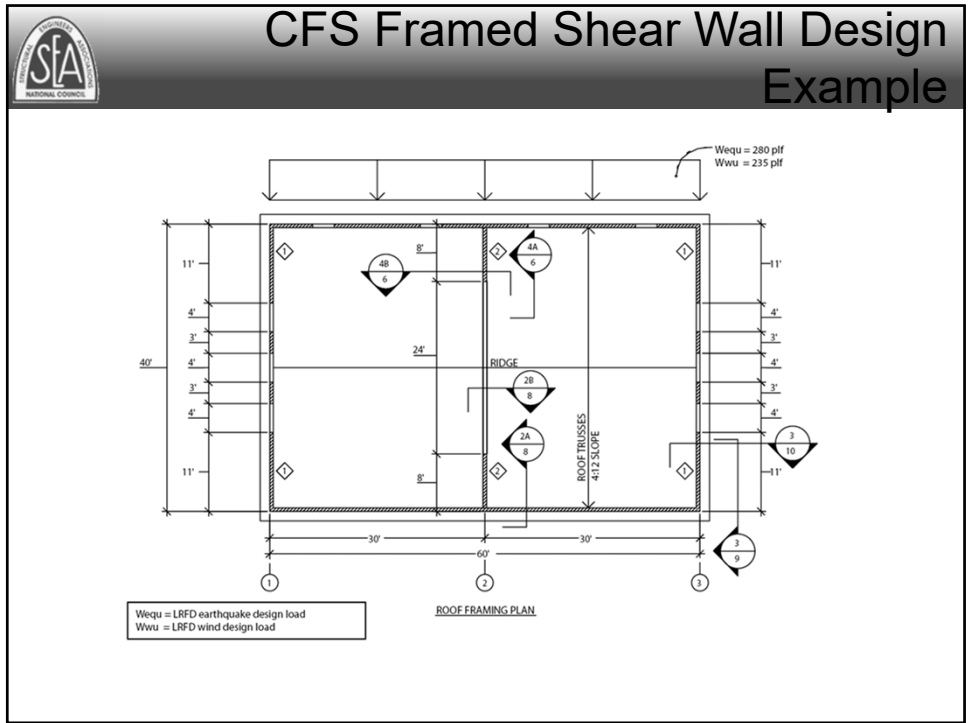

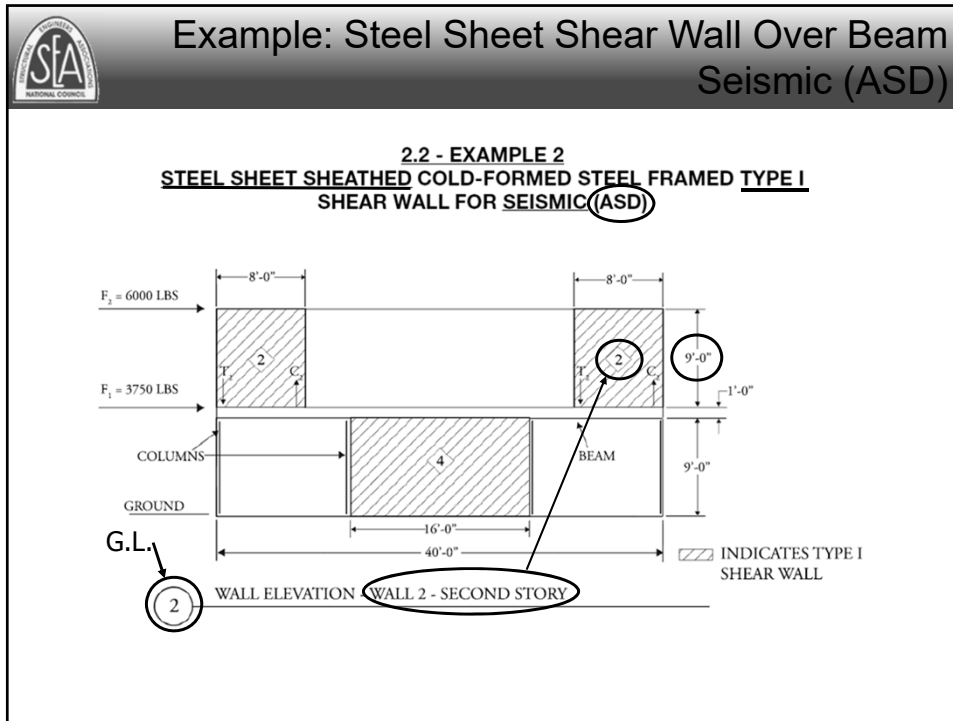

Example: Steel Sheet Shear Wall Over Beam Available Strength

Required Shear Strength:

Second Story:

| | |
|----------------------------------------------|------------------------------------------------------------|
| Seismic load to diaphragm (LRFD) | $w_{\infty} = 280$ plf |
| Seismic load to diaphragm (ASD) ¹ | $w_2 = w_{\infty} / 1.4 = 200$ plf |
| Tributary width | $W2 = 60 \text{ ft} / 2 = 30$ ft |
| Required allowable strength at Line 2 | $V_2 = F_2 = w_2 \times W_2 = 6000$ lbs |
| Total length of shear walls | $\Sigma L_{i_2} = 8 \text{ ft} + 8 \text{ ft} = 16$ ft |
| Required allowable unit shear strength | $v_2 = V_2 / \Sigma L_{i_2} = \underline{375 \text{ plf}}$ |

Available Shear Strength:

Shear wall aspect ratio = $h_2/w_2 = 9 \text{ ft} / 8 \text{ ft} = 1.13 : 1 < 2:1$ and $4:1$ OK

Use 0.027 inch steel sheet sheathing on one side of second story shear walls along Line 2 with screws at 4 inches o.c. Nominal strength = $R_{\infty} = 1000$ plf (AISI S213-07 Table C2.1-3)

Shear wall seismic safety factor $\Omega = 2.5$
 Available shear strength (ASD) $v = 1000 / \Omega = \underline{400 \text{ plf}} > 375 \text{ plf}$ OK



Example: Steel Sheet Shear Wall Over Beam Overturning

Required Overturning Strength (Neglecting gravity load effects for simplicity)¹:

| | |
|-----------------------------------------------------------------------------------------------------------------------------------------------|-------------------------------------------------------------------------------------------------------------------------------------------------------------|
| Shear wall overturning resisting moment arm ² | $d_2 = (8\text{ft} \times 12\text{in}/\text{ft}) - (2 \times (1.625\text{in})) - 1.5\text{in} = 91.3 \text{ in.}$ |
| Shear wall height | $h_2 = 9\text{ft} \times 12\text{in}/\text{ft} = 108 \text{ in.}$ |
| Required allowable shear strength ⁵ | $V_{w2} = V_w / 2$ shear walls = 3000 lbs |
| Required overturning strength when $R \leq 3$ (AISI S213-07 C5.1) | $T_2 = C_2 = V_{w2} \times (6.5 / 3.0) \times h_2 / d_2 = \mathbf{7690 \text{ lbs}}$ |
| Required overturning strength when $R > 3$ (AISI S213-07 C5.1) ⁷ | ASD OT = $V_{w2} \times h_2 / d_2 = 3549 \text{ lbs}$ |
| Use lesser of: | $T_2 = C_2 = \text{LRFD OT} \times \Omega_o = 3549 \text{ lbs} \times 1.4 \times 3.0 = 14,906 \text{ lbs}$ |
| 1. Overstrength factor ³ | OR |
| 2. Max. system can deliver ⁴ | $V_{w2} = R_{w2} \times L_2 = 1000 \text{ plf} \times 8 \text{ ft} = 8000 \text{ lbs}$ $T_2 = C_2 = V_{w2} \times h_2 / d_2 = \mathbf{9463 \text{ lbs}}$ |
| Required <u>strength of elements</u> Supporting <u>discontinuous</u> shear wall (neglecting gravity load effects for simplicity) ⁶ | $T_2 = C_2 = \text{LRFD OT} \times \Omega_o = (3549 \text{ lbs} \times 1.4) \times 3.0 = \mathbf{14,906 \text{ lbs}}$ |



Example: Steel Sheet Shear Wall Over Beam Vertical Discontinuity

ASCE 7-10 Commentary C12.3.3.3

The connection between the discontinuous element and the supporting member must be adequate to transmit the forces for which the discontinuous element was designed. For example, where the discontinuous element is required to comply with the special loads specified in Section 12.4.3, as is the case for steel columns in braced and steel moment frames, its connection to the supporting member will also be required to be designed to transmit the same forces. These same special seismic loads are not required for shear wall systems and, as such, the connection between the shear wall and the supporting member would only need to be designed to transmit the loads associated with the shear wall and not the special seismic loads.



Example: Steel Sheet Shear Wall Over Beam Overturning

C5.1 Shear Walls

Where steel or wood sheathing is provided for lateral resistance, the requirements of this section shall apply.

C5.1.1 Connections

C5.1.1.1: The *available strength* [*factored resistance*] of connections for *boundary members* and *collectors* shall exceed the following, as applicable:

(a) *In the United States and Mexico:* *Nominal* tensile strength of the member, but need not exceed the *amplified seismic load*.

C5.1.1.2: The pull-out resistance of screws shall not be used to resist seismic forces.

C5.1.2 Chord Studs and Anchorage

C5.1.2.1: *Studs* or other *vertical boundary members* at the ends of wall segments, that resist seismic loads, braced with sheathing, shall be anchored such that the bottom *track* is not required to resist uplift by bending of the track web.

C5.1.2.2: *Studs* or other *vertical boundary members* and uplift anchorage thereto shall have the *nominal strength* to resist the following, as applicable:

(a) *In the United States and Mexico:* Loads that the system can deliver, but need not exceed the *amplified seismic load*.

C5.1.3 Foundations

In the United States and Mexico: Foundations need not be designed to resist loads resulting from the amplified seismic loads.



Example: Steel Sheet Shear Wall Over Beam Compression Due to Overturning

Boundary Element (Neglecting gravity load effects)

Compression due to overturning

h = 9 ft
 Ly, Lt = 4.5 ft
 C1 = 9463 lbs (AISI S213-07 C5.3 – Max. system can deliver)

C-shape studs with steel bracing at mid-height designed per the AISI S211-07 *North American Standard for Cold-Formed Steel Framing – Wall Stud Design* (Ref. 8). Also reference the wall bracing design examples from the 2002 AISI Cold-Formed Steel Framing Design Guide (Ref. 12) and Bracing of Cold-Formed Steel Structures from ASCE (Ref. 13).

AISI S213-07 Section C5.1.1 states that vertical boundary elements should have nominal strength to resist the loads that the system can deliver, but not to exceed the amplified seismic load.

Use (2) 350S162-54 (Fy=50 ksi)

Nominal compression strength, P_n , from 2002 AISI Manual Table III-5
 $P_n = 6,210 \text{ lbs} \times 2 \text{ studs}^* = 12,420 \text{ lbs} > 9463 \text{ lbs}$ **OK**

* Shearwall boundary members are not typically attached per the requirements for built-up compression members in the NAS to achieve an increase in axial compression strength. Reference page 8 of this Design Guide regarding this discussion.



Example: Steel Sheet Shear Wall Over Beam Tension Due to Overturning

Overturning Restraint (Neglecting gravity load effects for simplicity)

Tension due to overturning
 T_o (from Ex. 2) = 9463 lbs (S213-07 C5.1.2 – Max. system can deliver)

AISI S213-07 Section C5.3 requires that the uplift anchorage have the nominal strength to resist the amplified seismic loads. ICC-ES AC 261 [20] has a procedure to determine the nominal strength of a connector for cold-formed steel construction using the average of the ultimate load of at least 3 tests. AISI S100 Chapter F defines the nominal strength of a tested member or connection as the average of at least 3 tests.

The 1997 UBC only had an LRFD load combination equation that included the system overstrength factor, Ω_o . ASCE7-05 has both an LRFD and a ASD load combination that include the overstrength factor. The 1997 UBC Section 1633.2.6 stated that an allowable stress increase of 1.7 and a phi factor of 1.0 could be used to determine the design strength of a collector used to resist the force determined using the LRFD load combinations with the overstrength factor. ASCE7-05 Section 12.4.3.3 permits a 1.2 allowable stress increase when using the ASD load combinations with the overstrength factor. The 1.2 is a soft conversion from strength level to ASD level ($1.7 / 1.4 = 1.2$).

In this example, the ASCE7 LRFD load combinations with the overstrength factor were used and the pre-fabricated hold-down has a published tabulated nominal load value. If the ASCE7 ASD load combinations with the overstrength factor were used one would use the pre-fabricated hold-down ASD capacity multiplied by 1.2, not the hold-down nominal capacity, in accordance with ASCE7-05 12.4.3.3.

Try prefabricated SHD1 hold-down (See Appendix A on page 55) to 2 – 54 mil back to back end studs

Nominal hold-down tensile strength = 29,888 lbs > 9463 lbs OK

Check hold-down anchor bolt nominal tension strength

7/8 inch diameter A307 or A36 anchor bolt
 AISI 360-05 J3.6 [10]
 $T_a = F_u A_n = 0.75 \times F_u \times A_n = 0.75 \times 58 \text{ ksi} \times 0.601 \text{ in}^2 = 26,144 \text{ lbs} > 9463 \text{ lbs}$ OK



Example: Steel Sheet Shear Wall Over Beam Amplified Seismic Load

AISI S213-07/S1-09 Sections A2 & C5.1.2 – LRFD Combination w/ Ω_o

A2 Definitions

Where terms appear in this standard in italics, such terms shall have meaning as defined in AISI S200 or as defined herein. Where a country is indicated in brackets following the definition, the definition shall apply only in the country indicated. Where terms are not italicized, such terms shall have ordinary accepted meaning in the context for which they are intended.

Amplified Seismic Load. Load determined in accordance with the applicable building code load combinations that include the system overstrength factor, Ω_o , for strength design (LRFD).

C5.1.2 Chord Studs and Anchorage

C5.1.2.1: *Studs* or other vertical *boundary members* at the ends of wall segments, that resist seismic loads, braced with sheathing, shall be anchored such that the bottom *track* is not required to resist uplift by bending of the *track web*.

C5.1.2.2: *Studs* or other vertical *boundary members* and uplift anchorage thereto shall have the nominal strength to resist the following, as applicable:

(a) *In the United States and Mexico:* Loads that the system can deliver, but need not exceed the *amplified seismic load*.



Example: Steel Sheet Shear Wall Over Beam Amplified Seismic Load

LRFD capacity to resist this load.
S213 permits nominal strength
(CFS Shear Wall's)

→

Basic Combinations for Strength Design with Overstrength Factor (see Sections 2.3.2 and 2.2 for notation).

5. $(1.2 + 0.2S_{DS})D + \Omega_e Q_E + L + 0.2S$
 7. $(0.9 - 0.2S_{DS})D + \Omega_e Q_E + 1.6H$

NOTES:

1. The load factor on L in combination 5 is permitted to equal 0.5 for all occupancies in which L_o in Table 4-1 is less than or equal to 100 psf (4.79 kN/m²), with the exception of garages or areas occupied as places of public assembly.
2. The load factor on H shall be set equal to zero in combination 7 if the structural action due to H counteracts that due to E . Where lateral earth pressure provides resistance to structural actions from other forces, it shall not be included in H but shall be included in the design resistance.



Example: Steel Sheet Shear Wall Over Beam Amplified Seismic Load

ASD capacity x 1.2

- While not addressed in S213, one might make the case to use Nominal / 1.4 capacity to resist ASD overstrength combinations

→

Basic Combinations for Allowable Stress Design with Overstrength Factor (see Sections 2.4.1 and 2.2 for notation).

5. $(1.0 + 0.14S_{DS})D + H + F + 0.7\Omega_e Q_E$
 6. $(1.0 + 0.105S_{DS})D + H + F + 0.525\Omega_e Q_E + 0.75L + 0.75(L_o \text{ or } S \text{ or } R)$
 8. $(0.6 - 0.14S_{DS})D + 0.7\Omega_e Q_E + H$

12.4.3.3 Allowable Stress Increase for Load Combinations with Overstrength

Where allowable stress design methodologies are used with the seismic load effect defined in Section 12.4.3 applied in load combinations 5, 6, or 8 of Section 2.4.1, allowable stresses are permitted to be determined using an allowable stress increase of 1.2. This increase shall not be combined with increases in allowable stresses or load combination reductions otherwise permitted by this standard or the material reference document except for increases due to adjustment factors in accordance with AF&PA NDS.

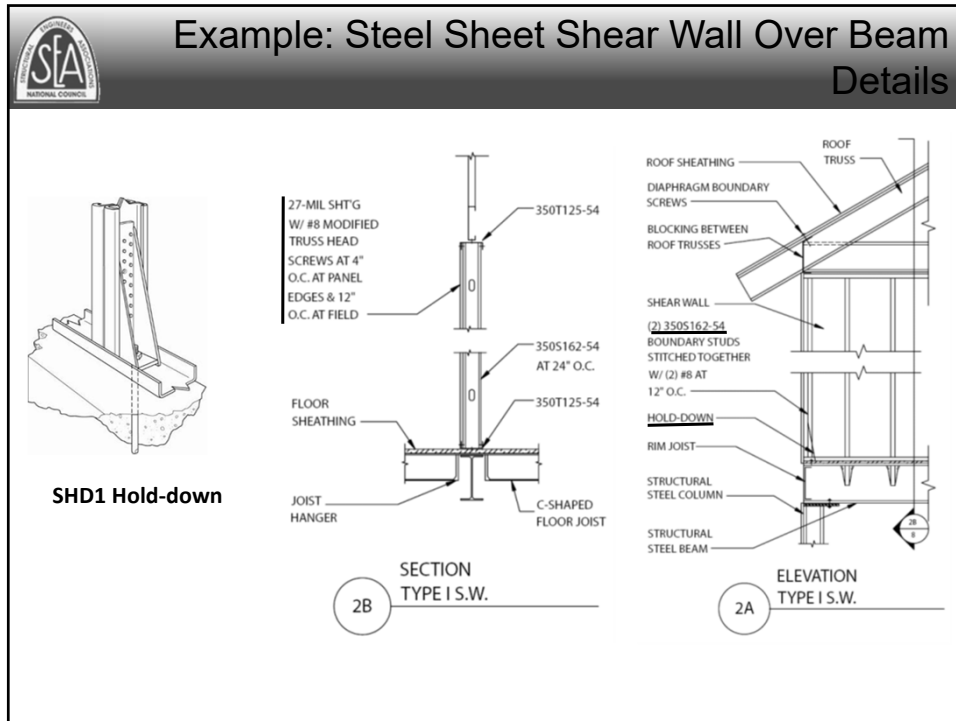

CFS vs. Wood Framed Shear Walls

SUMMARY:

1. Lateral Standard: AISI S213 rather than AWC SDPWS.
2. Shear wall & diaphragm provisions similar to wood with some differences.
3. Shear wall & diaphragm strength values similar to wood with some differences.
4. Shear wall & diaphragm deflection equations similar to wood with some differences.
5. $R > 3$ shear walls require collector connections, chord studs, tie-downs have the nominal strength to resist the amplified seismic load.
6. Continuous rod tie-down systems offer greater strength than typical tie-downs for higher loads due to multi-story construction.
7. Axially and laterally loaded studs may require intermediate bracing. Bracing force is cumulative for axially loaded studs so requires periodic anchorage to the structure.
8. Shear transfer design and detailing may be challenging for hybrid structures.
9. Design concrete anchorage for the bolt selected as required by AISI S213 (e.g., 1" dia ASTM 193 B7 ($F_u=125$ ksi)).

108



Available for purchase



SEAOC 2015 IBC Structural/Seismic Design Manual Volumes 1-3

Buy your copies now at
seaoc.org/bookstore

109



Cold-Formed Steel Engineers Institute



CFSEI.ORG

- Technical Notes
- Design Guides
- Engineer Finder
- Newsletters
- Details (.dwg)
- Upcoming Events
- Publication Discount



Questions?



111



THANK YOU!

112

112