



An Introduction to the New ASCE Solar PV Structures Manual of Practice

Steve Gartner P.E., M. ASCE

Principal Engineer Renewable Energy, HDR

Chair ASCE Solar PV Structures Committee

steven.gartner@hdrinc.com



1. Become familiar with the fundamentals of a solar PV plant.
2. Identify the different types of solar PV structures.
3. Know the unique aspects of solar PV structures and why a Manual of Practice is needed.
4. Learn about some key challenges that the solar PV industry faces including corrosion of steel piles, bolt tensioning, and frost jacking of pile foundations.



Learning Objectives

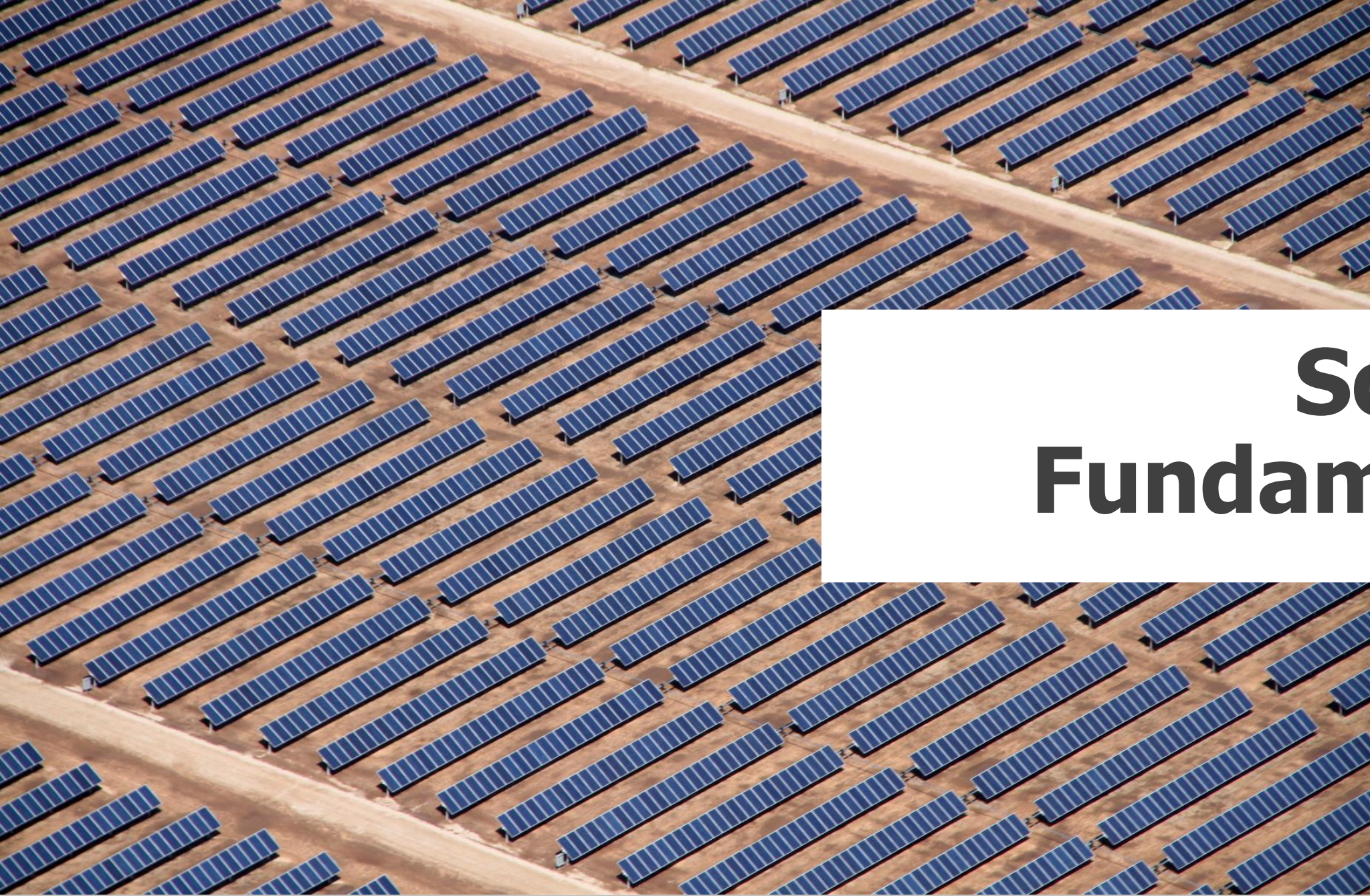

Solar PV Fundamentals

What does "Solar PV" refer to?

PV = Photovoltaic*

(not concentrated solar)

*Energy from sunlight creates an electrical charge in a solar cell. This electricity is then collected (sometimes stored for a short time) and then transported for use by a consumer.

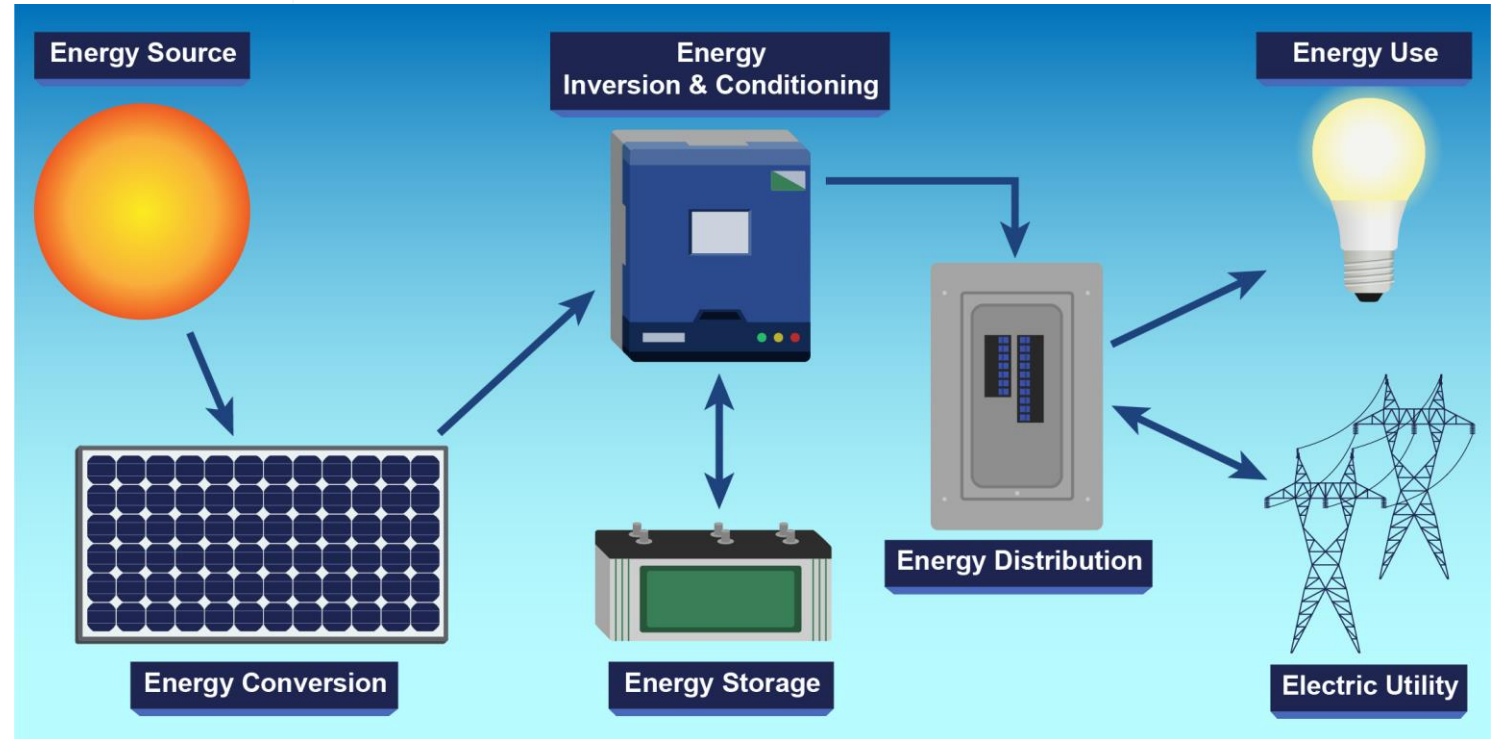

[pv_system.png \(2201x1100\) \(ucf.edu\)](#)

Solar PV Cells, Panels, Modules, and Arrays

- **Cell:** semiconductor that produces DC electricity when exposed to the sun.
- **Module:** multiple cell circuits sealed behind glass.
- **Panel:** more than 1 module electrically wired together.
- **Array:** multiple panels electrically wired together to form a power generating unit.

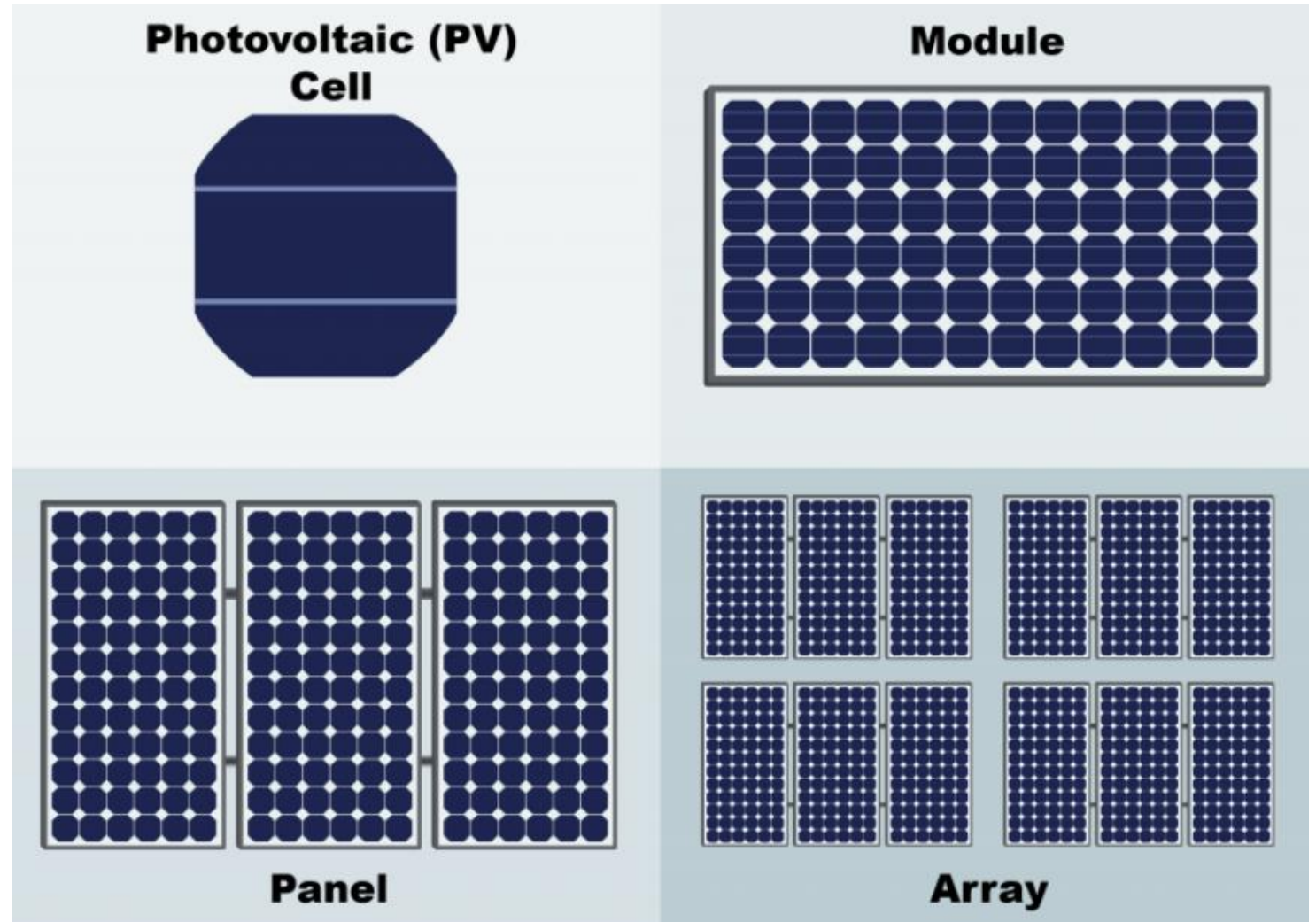

Balance of System (BOS)

- **Power Conversion System (PCS):** Skid that includes an inverter and transformer. Rooftop and smaller installations have *string inverters*.
- **Combiner Box:** Where small DC wires are combined into a larger DC cable.
- **Meteorological Station:** $\geq 3\text{m}$ tall; measures weather data.
- **Battery Energy Storage System (BESS):** System that stores electricity that is produced during the day.





Solar PV Support Structures

Ground-Mounted *Trackers*

- **Single Axis:**
 - Torque tube runs along length of the tracker row.
 - Faces East in the morning and West in the evening.
 - Steel piles embedded ~5ft - 15ft into the ground.
- **Dual Axis:**
 - Has more moving parts than single axis.
 - Generally costs more than single axis.
 - Typically uses concrete pier foundations.



Ground-Mounted *Fixed Tilt*

- Always face south.
(in the northern hemisphere)
- No moving parts.
- Does not generate as much electricity as trackers.
- Is more “forgiving” when pile settlement occurs.



Ground-Mounted *Ballasted*

- Specialized Fixed Tilt racking system.
- Typically has concrete ballast foundations.
- Landfills and brownfields where an environmental “cap” cannot be penetrated.

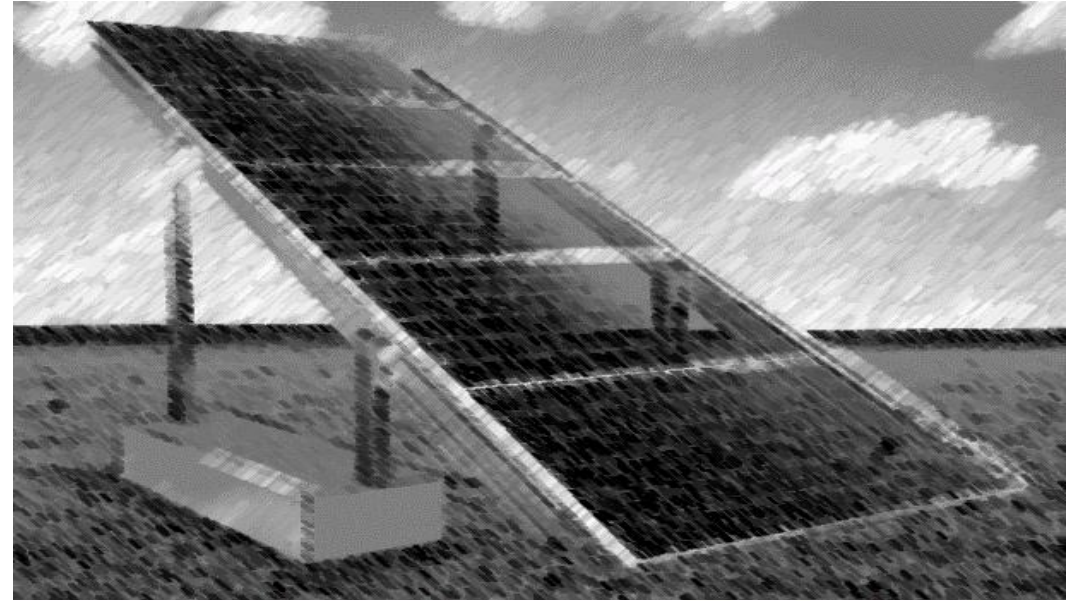

[TYPES OF SOLAR STRUCTURES \(safearth.in\)](http://safearth.in)

Elevated

- Clear height > 7'-6"
- Carports / Canopies
 - Allows for vehicles to park underneath.
 - Can be coupled with electric vehicle (EV) charging stations.
- Agrivoltaics (w/ Clear Height > 7'-6")
 - Allows for farming to occur under the PV modules.
 - Grazing land for livestock
 - Crops for harvesting



Rooftop

- Multiple types of mounting systems and racks.
 - Directly attach to the roof structure.
 - Ballasted systems sit on the roofing material.



Floating

- PV Modules are attached to racks that sit on floats.
- Need to be moored to shore or bottom of the waterway.
- Reduces evaporation and algae growth.
- Costs more than ground-mounted (as of 2023) but is option for areas with open water and limited land.
- Still new in the United States with limited code guidance for structural and electrical design.



Construction approaches for Ohio's first floating solar project (solarpowerworldonline.com)
Largest floating solar array in North America now online in New Jersey (solarpowerworldonline.com)



Solar PV Structures Manual of Practice

ASCE Solar PV Structures Committee

Team of ***VOLUNTEERS***

- 30 Voting members
- 16 Associate members (non-voting)

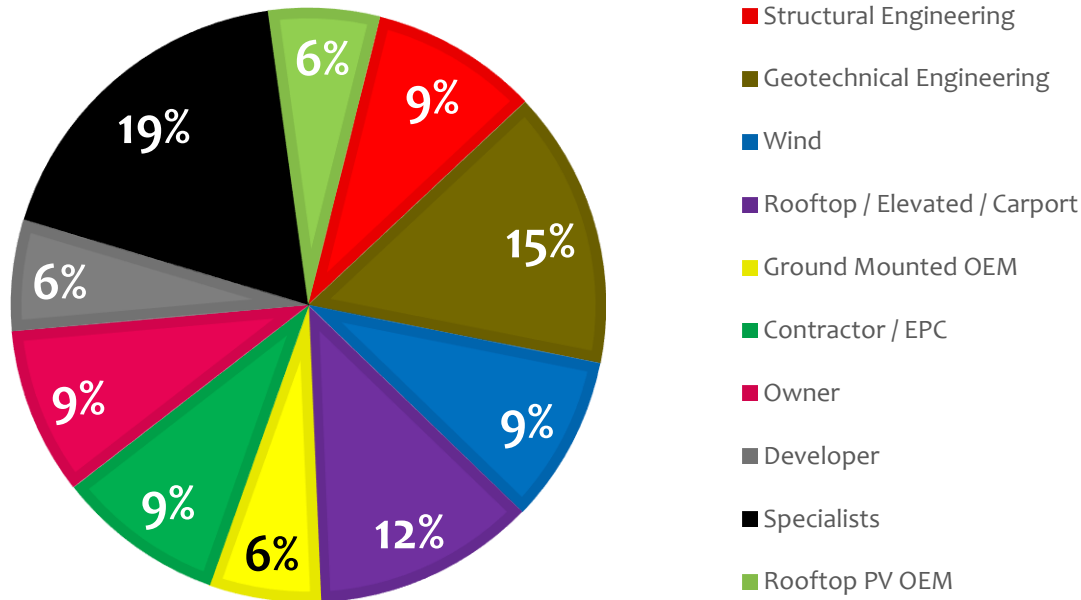

Purpose

- Share lessons learned
- Develop design guides, Manuals of Practice, and standards.
- Promote the reliable and consistent design of solar PV structures.
- *Note:*
 - Does not perform research
- Website: [Solar PV Structures | ASCE](#)

ASCE Solar PV Structures Committee

“Sharpening the Solar PV pencil”



Unique structural systems:

- Economy of Scale
- Lightweight “wind sails”
 - Low mass -> low stiffness
- Design life 25 – 40 years (ish...)
- Equipment / no occupants
 - Life Safety vs Economic Safety

ASCE Solar PV Structures Committee

Economy of Scale

Example:

- Assume steel ~\$0.85 / lbs
- ~80,000 piles
- Average: W6x9 piles @ 15ft long
- Steel ~ \$9.2M
- If piles increase to:
 - W6x10.5 => 17% increase in steel
 - W6x12 => 33% increase in steel

- Change pile size:
 - W6x9 => W6x10.5
 - +\$1.5M
 - W6x9 => W6x12
 - +\$3.1M
- Change pile size *and* length:
 - W6x9 => W6x10.5 @ 20 ft long
 - +\$5.1M
 - W6x9 => W6x12 @ 20 ft long
 - +\$7.1M

State of the Practice of Solar PV Structural Guidance

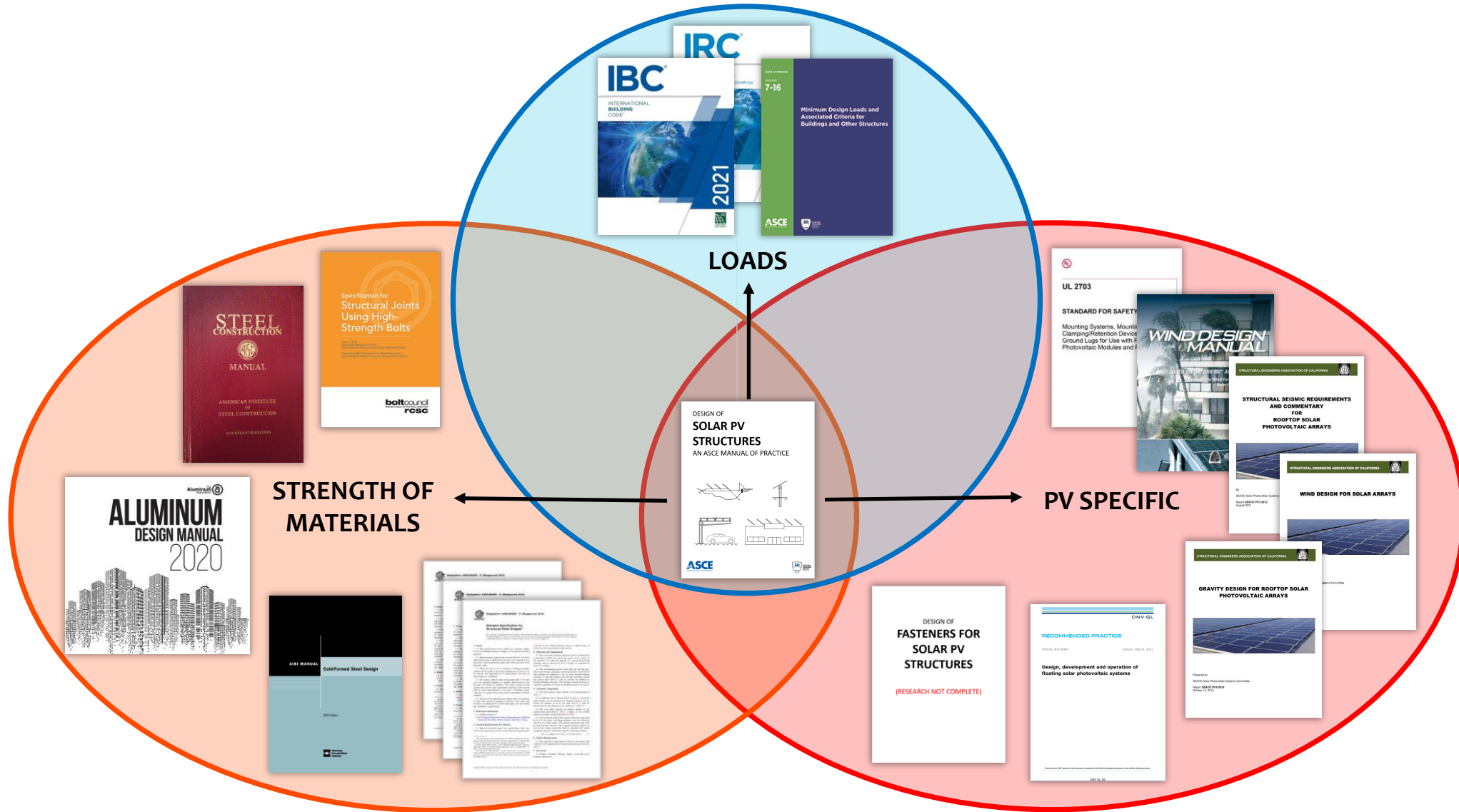

Manual of Practice

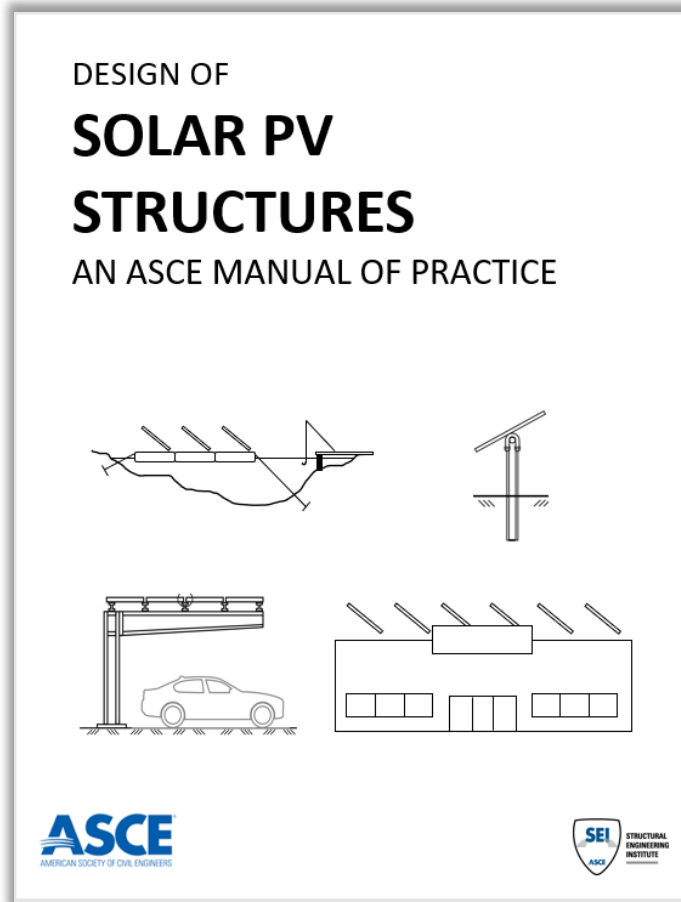

Actual cover will be different than the one shown above.

Manual of Practice → *Not a Standard*

Author → *Solar PV Structures Committee*

Sponsor → *Structural Engineering Institute*

Peer Review → *Blue Ribbon Panel*

****SEI Executive Committee Approval**

Manual of Practice

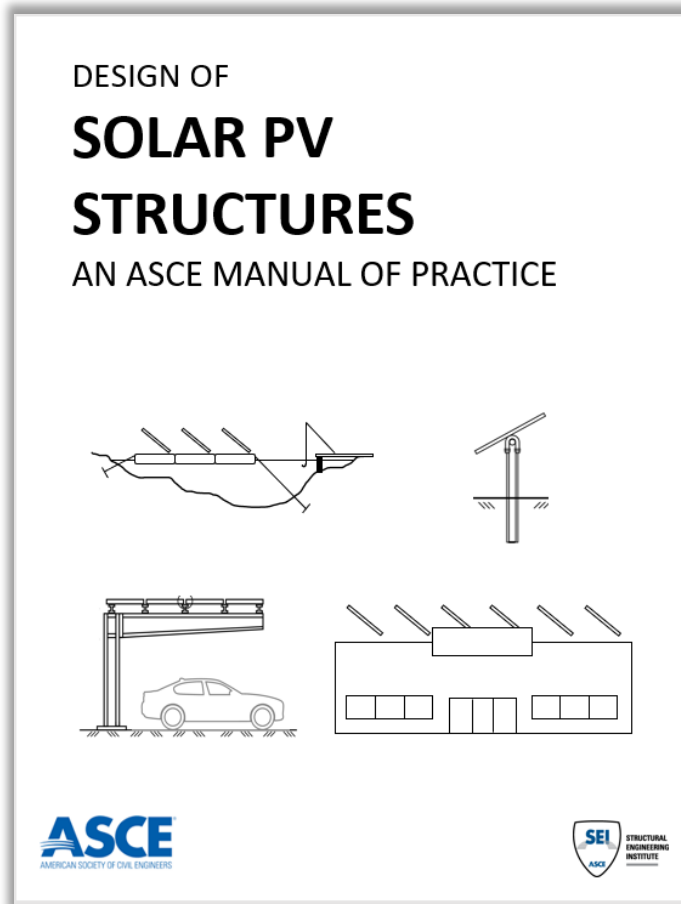

Actual cover will be different than the one shown above.

- A collection of:
 - Interpretations of existing codes & standards
 - Industry lessons learned
- Reference existing codes and standards.
- Will not duplicate what is already written.
- Fill in any “gaps” that may be in existing codes and standards.

Manual of Practice

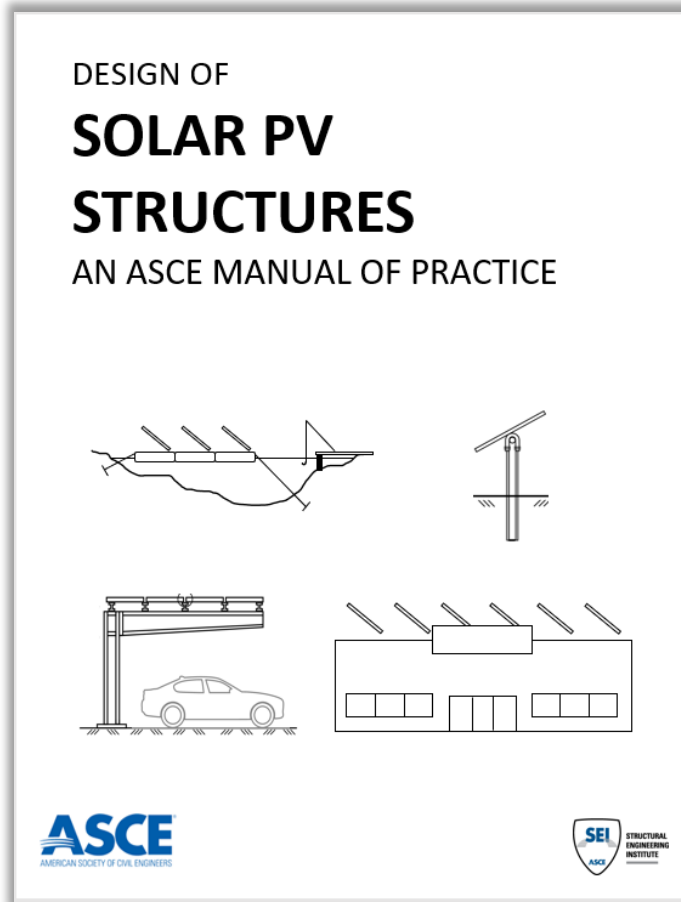

Actual cover will be different than the one shown above.

Chapter 1: Introduction

Chapter 2: Design Loads

Chapter 3: Corrosion

Chapter 4: Structural Design

Chapter 5: Foundation Design

Chapter 6: Construction Quality Control

Chapter 2: Design Loads



2.4 Dynamic Loads

- ALL Solar PV Structures to account for dynamic (wind) loads.

2.5 Flood Effects

- Flood loads per ASCE 7
- Scour effects on piles
- Per ASCE 7-22, if Risk Category II → 500 year Flood Load if located in FEMA flood hazard area.

Chapter 2: Design Loads

2.6 Frost Jacking Loads

- 3 things to occur at same time:
 - Soil temperature < 32 F
 - Soil that wicks water up from below
 - Available source of water from below
- Ice lenses form @ frozen / unfrozen layer.
- As lens grows everything above the lens gets pushed upward.

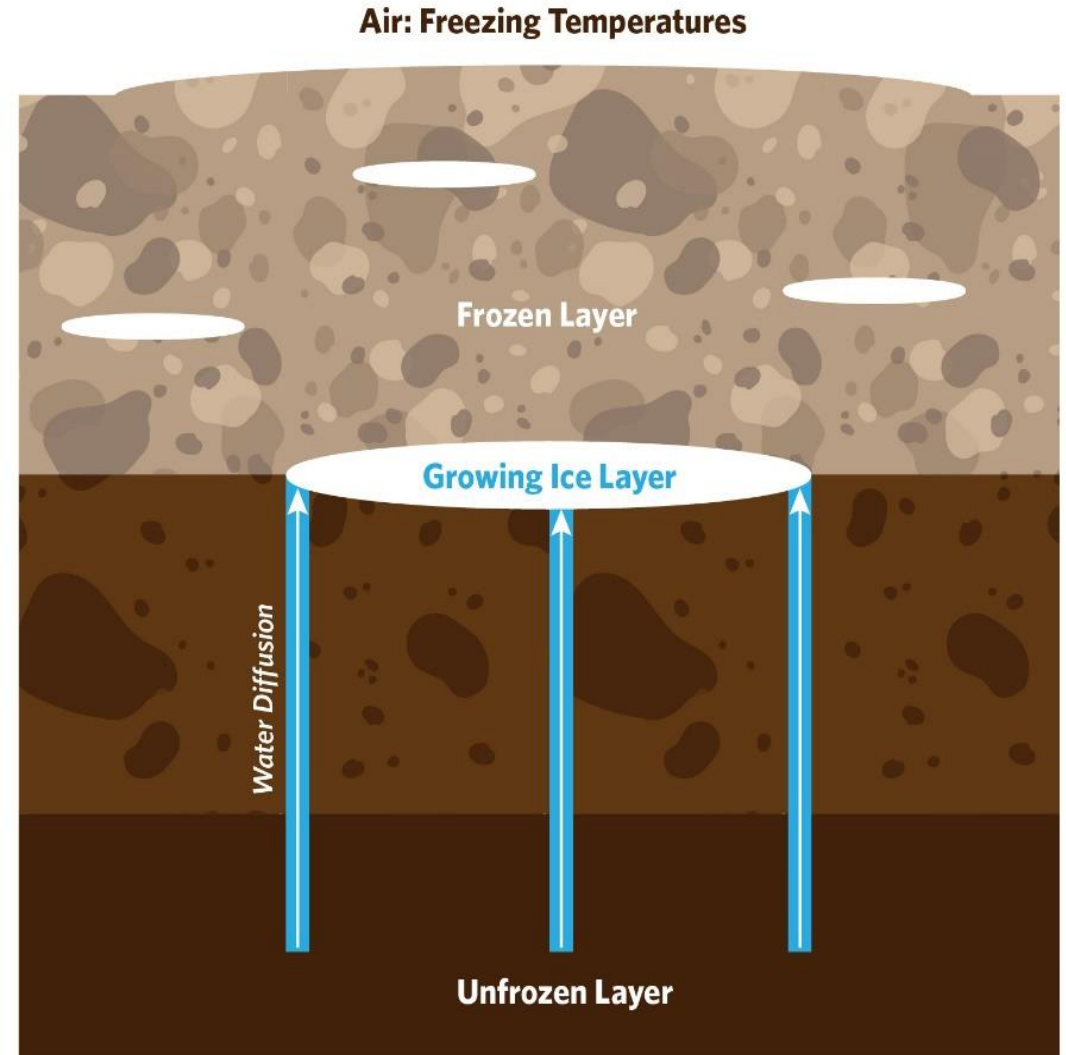

Chapter 2: Design Loads

2.6 Frost Jacking Loads

- Adfreeze Depth vs Frost Depth
- Incorporate MRI of **depth of frozen soil**
- References:
 - UFC Soil Mechanics Design Manual 7.1
 - Bowles, J.E., Foundation Analysis and Design, 5th Edition.
 - DeGaetano, et al., Atlas of Soil Freezing Depth Extremes for the Northeastern United States.

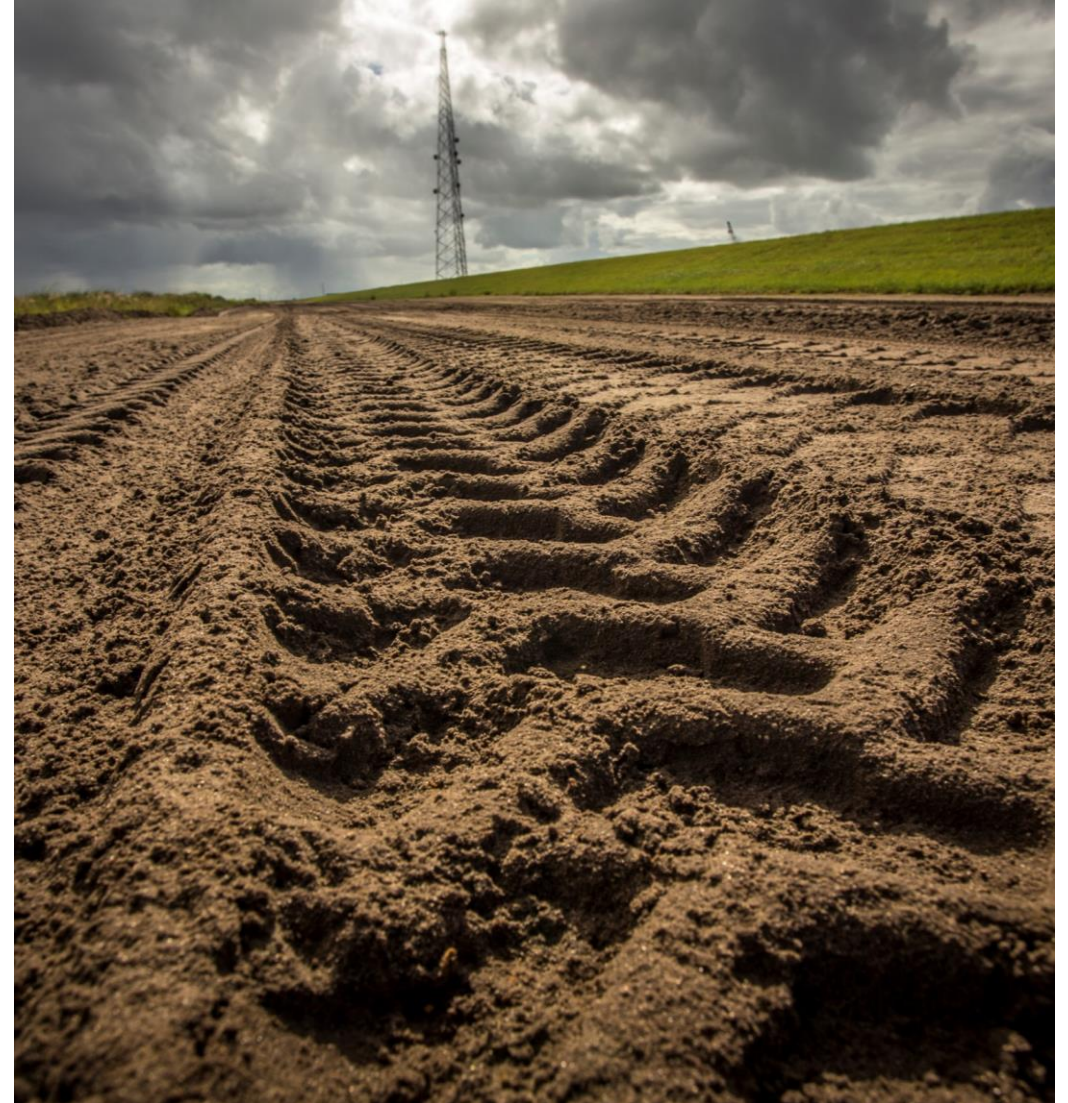

Chapter 2: Design Loads

2.6 Frost Jacking Loads

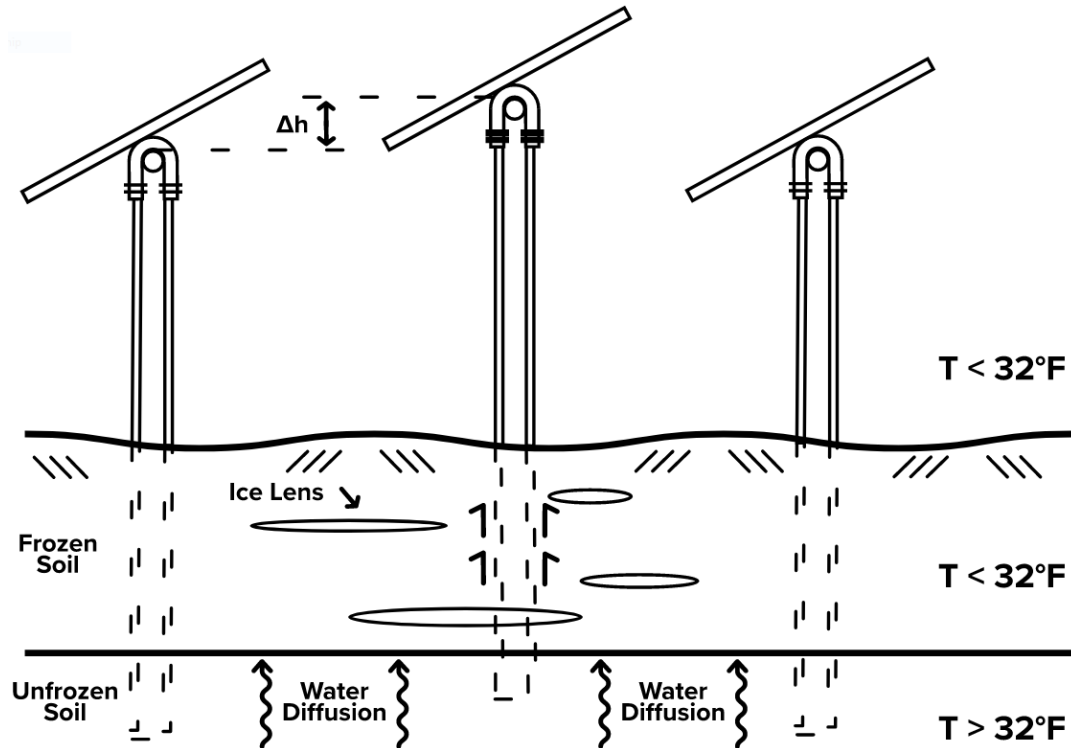

- Adfreeze bond stress vs soil frost susceptibility
 - Adfreeze bond stress from current literature.
 - Soil frost susceptibility
 - ASTM D5918
 - Current pavement design
 - Need more research!

Chapter 2: Design Loads

2.8 Seismic Loads

- Rooftop
 - ASCE 7, Chapter 13
 - Attached PV racks
 - Unattached / Fully ballasted PV racks
 - Partially attached PV racks

- Ground-mounted
 - ASCE 7, Chapter 15
 - Controls design of tracker pile weak axis in moderately to high seismic areas.
 - Rigidity analysis
 - Weak axis shear per pile, $V \frac{R_{yy}}{\sum R_{yy}} = V \frac{I_{yy}}{\sum I_{yy}}$
 - Liquefaction of soils
 - ASCE 7, Section C12.13.9

Chapter 2: Design Loads

2.9 Messenger Wire Loads

- Snow Loads
 - ASCE 7, Chapter 7
- Ice Loads
 - ASCE 7, Chapter 10

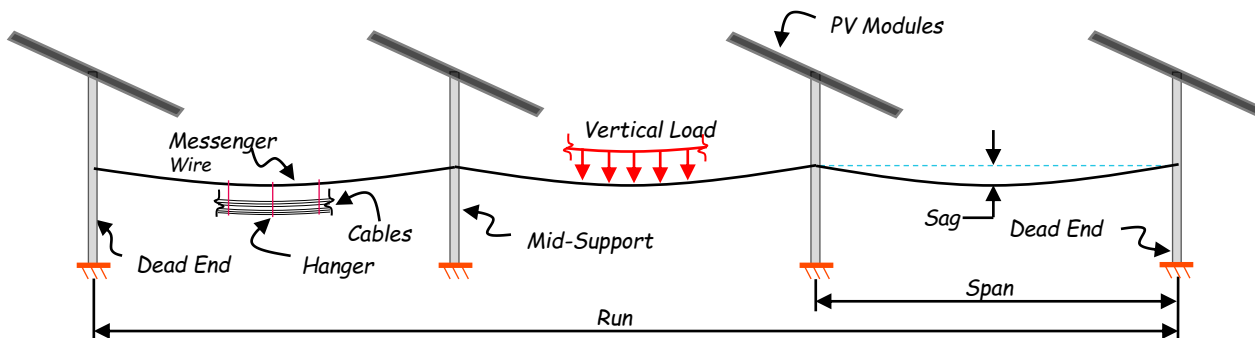

Example messenger wire system (courtesy of CAB Products).

Chapter 2: Design Loads

2.9 Messenger Wire Loads

- Snow Loads
- ASCE 7, Chapter 7



View of cables in a messenger wire hanger.
(Courtesy of CAB Products)

- ASCE 7-22, Figure 7.13-2

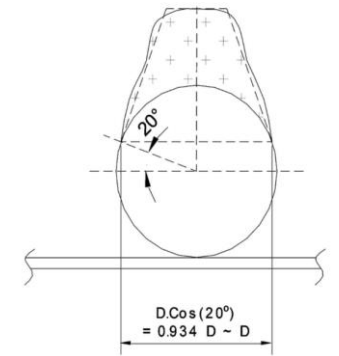

- ASCE 7-22, Figure 7.13-3

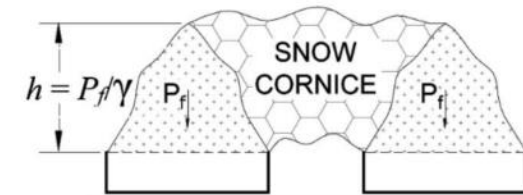

- Snow is assumed to blow off or melt between snow events.
- Need more research!

Chapter 2: Design Loads

2.9 Messenger Wire Loads

- Ice Loads
 - ASCE 7-22, Chapter 10
 - **Method 1:** Assume ice forms around every cable.
 - **Method 2:** Assume ice forms around outer surface of group of cables but not in the interior of the group.
 - **Method 3:** Assume cable group acts as tightly bound (perfectly round) wire bundle.
 - **Method 4:** "Rubber Band" method where ice is located around the cables just as a rubber band would lay if it was wrapped around the cable group.
 - Need more research!

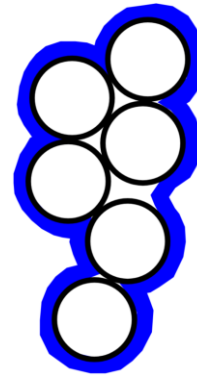

Method 2

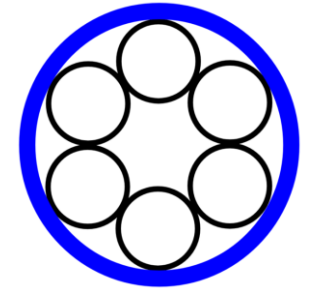

Method 3

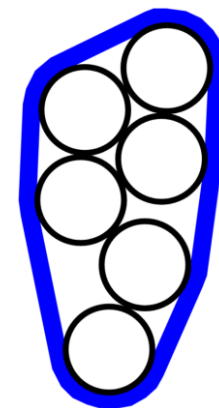

Method 4

Chapter 2: Design Loads

2.12 Wind Loads

- Interpretations of ASCE 7

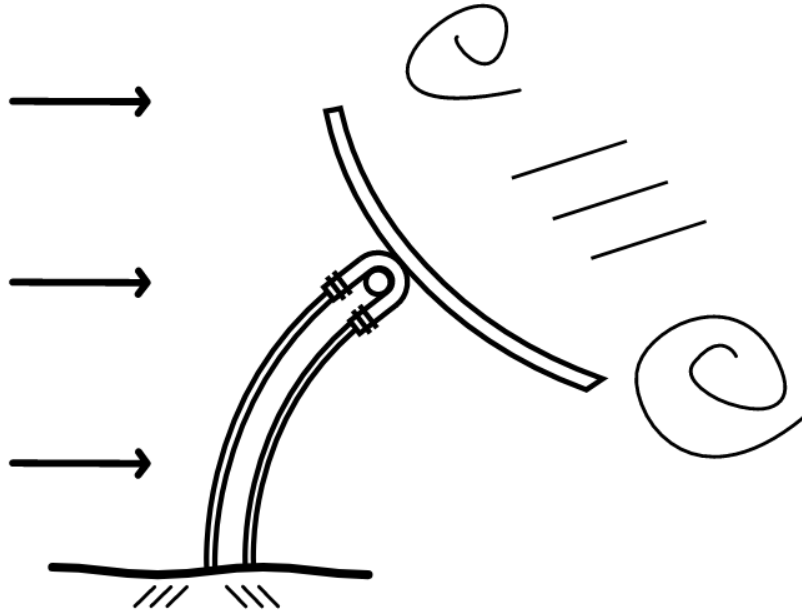

- Wind tunnel testing
- Topographic effects
- Directionality, K_d
- Effective wind area for attached and ballasted rooftop racking systems
- Ground-mounted structures
- Stiffness driven instability
- Need more Research!

Chapter 2: Design Loads

2.12 Wind Loads

- Wind dynamics
 - Torsional instability
 - Single-Axis Trackers
 - Vortex shedding
- Fixed Tilt structures
- Elevated (Carports)

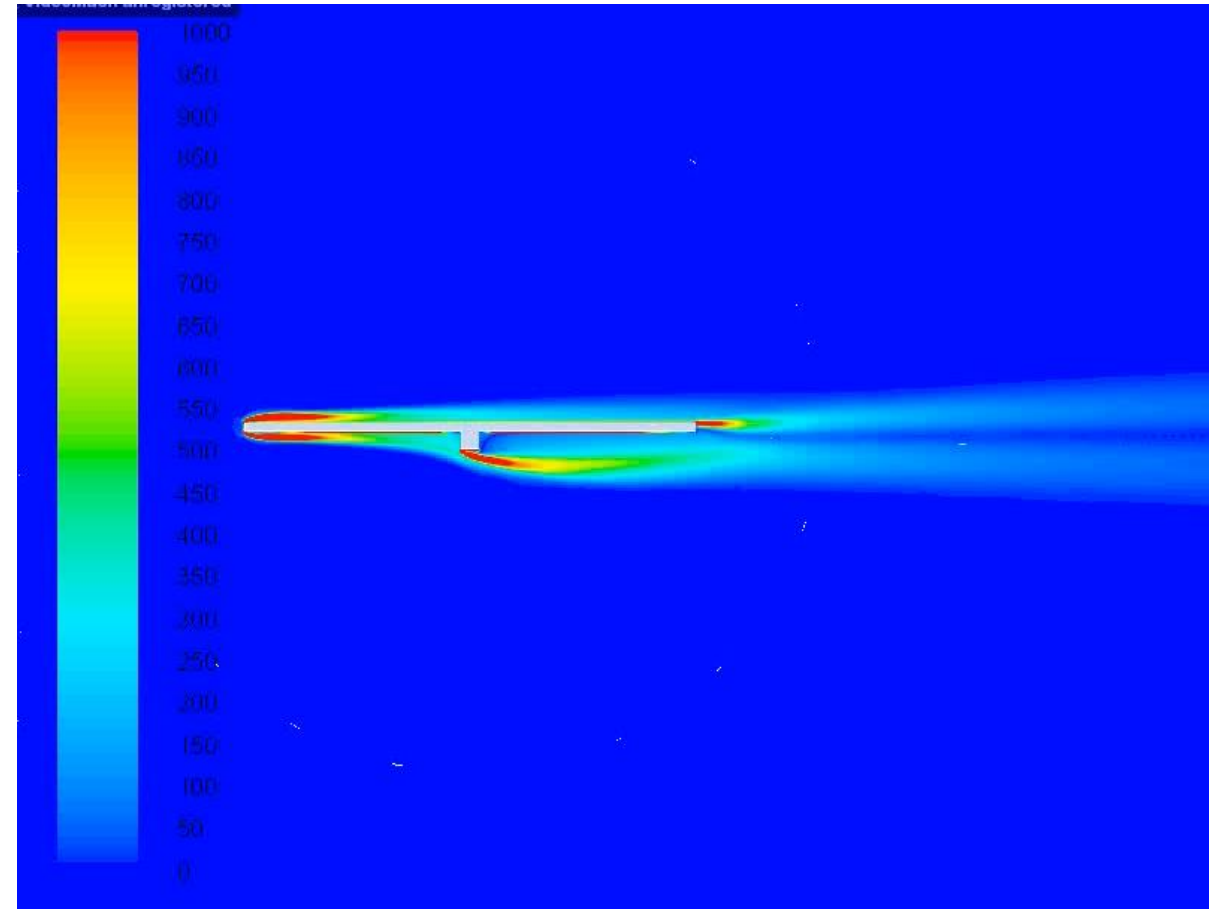
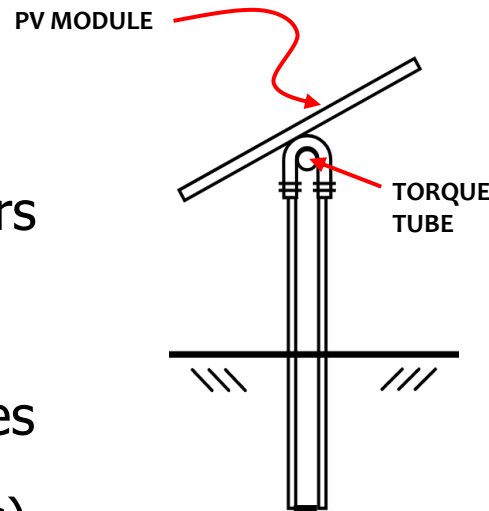

(Video Courtesy of CPP: [Home - CPP Wind](#))

Reference: Rohr, Bourke, Banks. 2015. Torsional Instability of Single-Axis Solar Tracking Systems. 14th International Conference on Wind Engineering, June 21-26, 2015.

Chapter 3: Corrosion

3.6 Corrosion Rate Estimation

- *ALL Solar PV Structures are to have corrosion considered during design.*
- **3.6.1 Atmospheric Corrosion Rate**
- **3.6.2 Below Grade Corrosion Rate**
 - 3.6.2.1 Similitude Analysis per Romanoff
 - 3.6.2.2 Prescriptive Methods
 - 3.6.2.3 Empirical Equations
- Need more research!

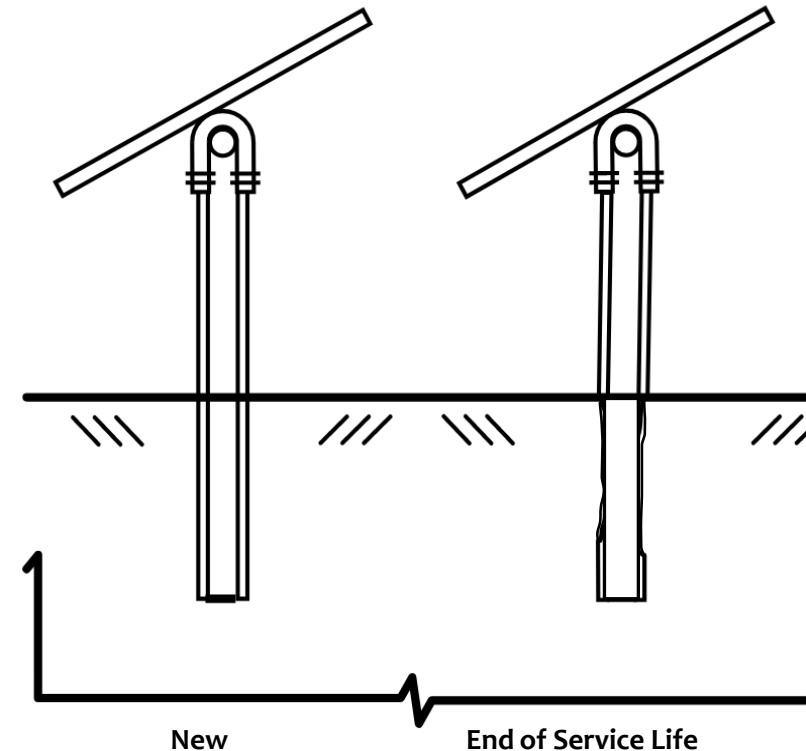

Chapter 4: Structural Design

4.3 Rationality

- *ALL Solar PV Structures are to be designed based on a rational design methodology that follows well-established principles of mechanics and be evidence-based.*
- Phase out "Factor of Safety" mindset
- Start using a "Rational Design" mindset
- *"Relying on a Factor of Safety (FS) is not reliable."*

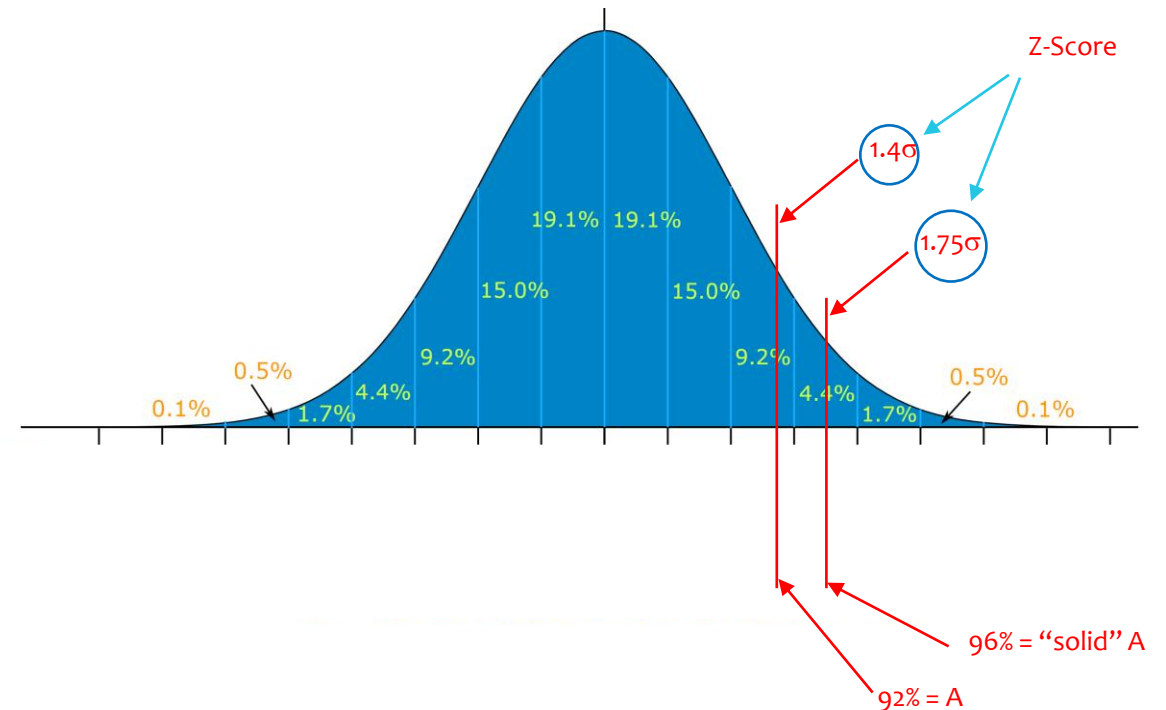

<https://hassmccook.medium.com/the-bitcoin-bell-curve-a-long-term-solution-to-global-wealth-income-inequality-de995929e267>

Chapter 4: Structural Design

4.7 Stability of Cantilevered Piles

- Structural Point of Fixity *vs* Geotechnical Point of Fixity
- Effective Length Method (ELM) *vs* Direct Analysis Method (DAM)
- Lateral Torsional Buckling
 - Compression Flange Length, L_{comp}

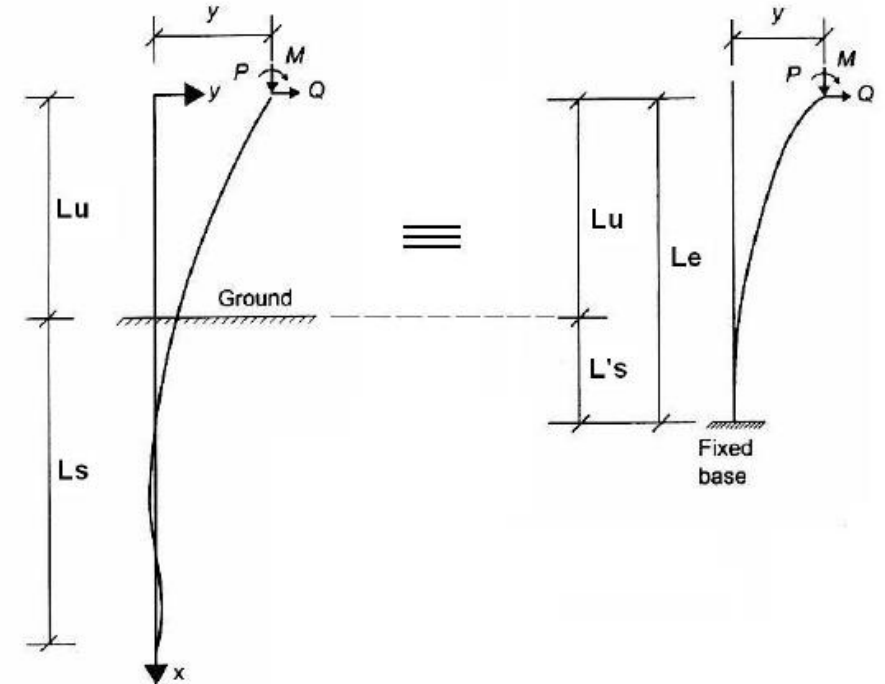

Davisson and Robinson. Bending and Buckling of Partially Embedded Piles.

Chapter 4: Structural Design

4.9.2 Floating PV (FPV) Structures

- Introduction to FPV structural design

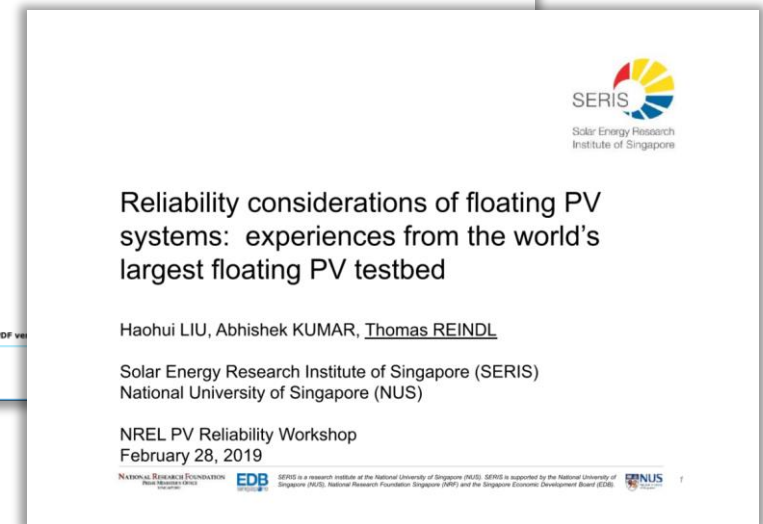
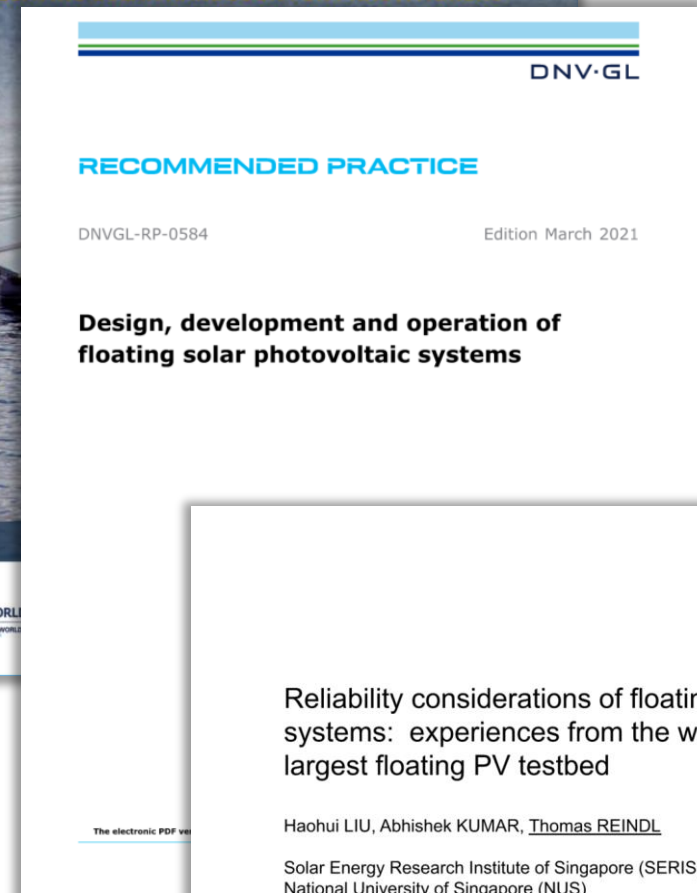
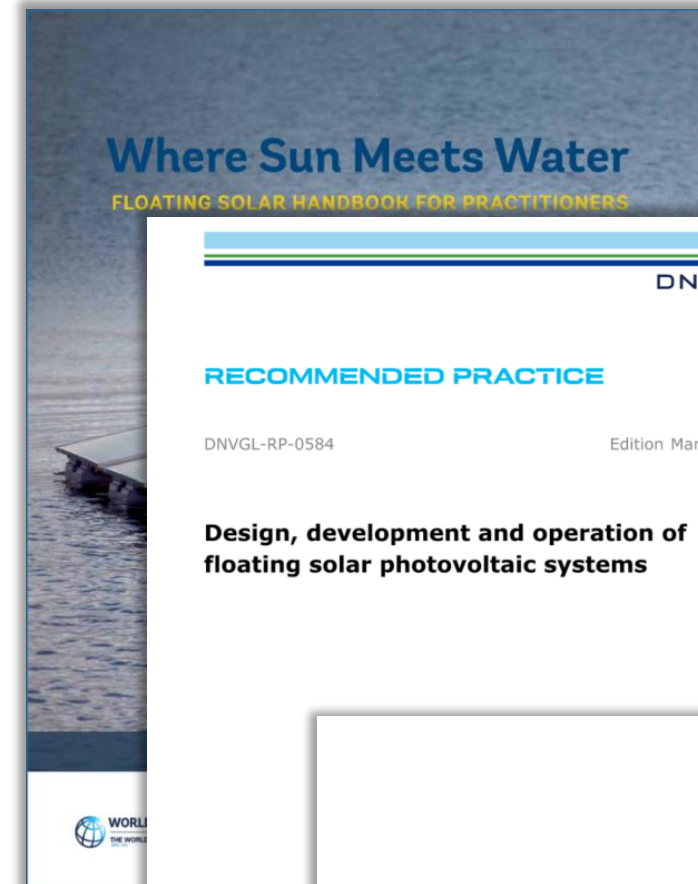
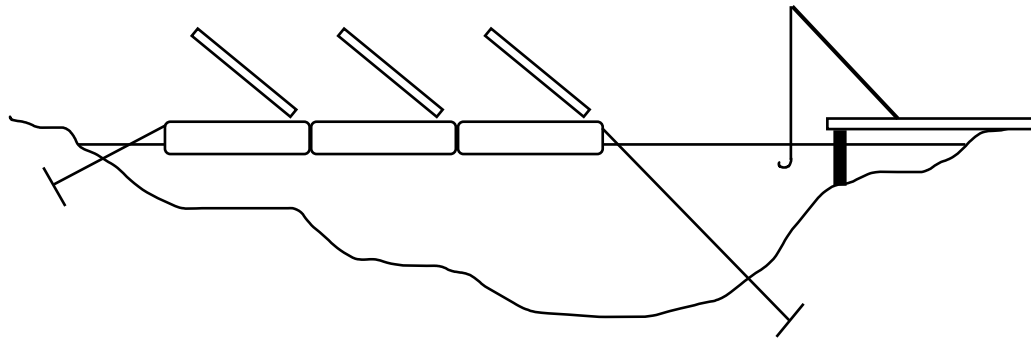

Chapter 4: Structural Design

4.9.4 Rooftop Solar Structures

- Complement existing standards
 - ASCE 7
 - SEAOC PV1-2012 (Seismic)
 - SEAOC PV2-2017 (Wind)
 - SEAOC PV3-2019 (Gravity)
- Fill in a few “gaps” from what current literature provides.

[Home - Structural Engineers Association of California \(seaoc.org\)](http://seaoc.org)

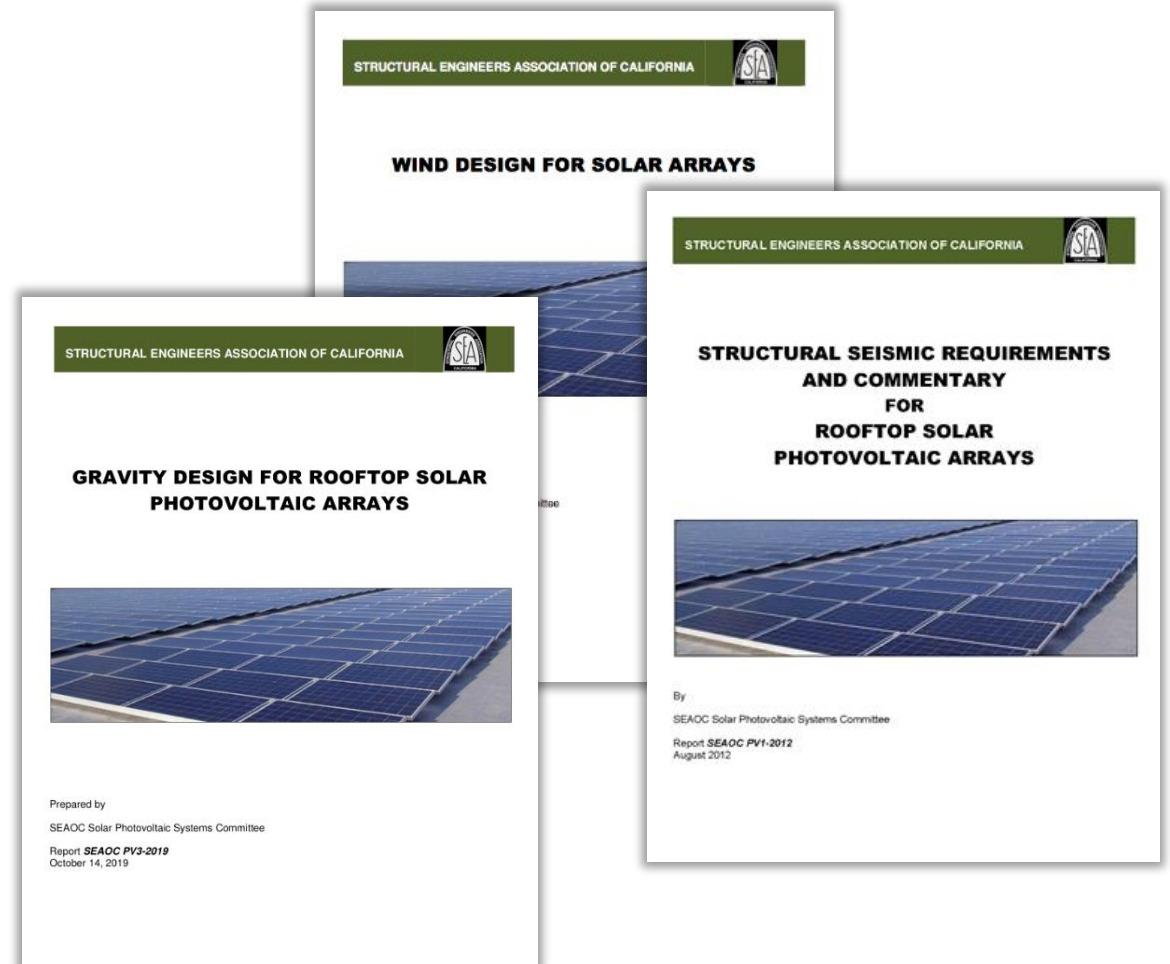

Chapter 4: Structural Design

4.11.2 Bolted Connections

- Focus on the tension in the bolt
- Pretension bolts where feasible.
 - Can break bolt if $< 1/2'' \phi$
- Adjust to the material type:
 - Alloy Bolts: 75% of Proof Load
 - Stainless Steel: 75% of Min Yield

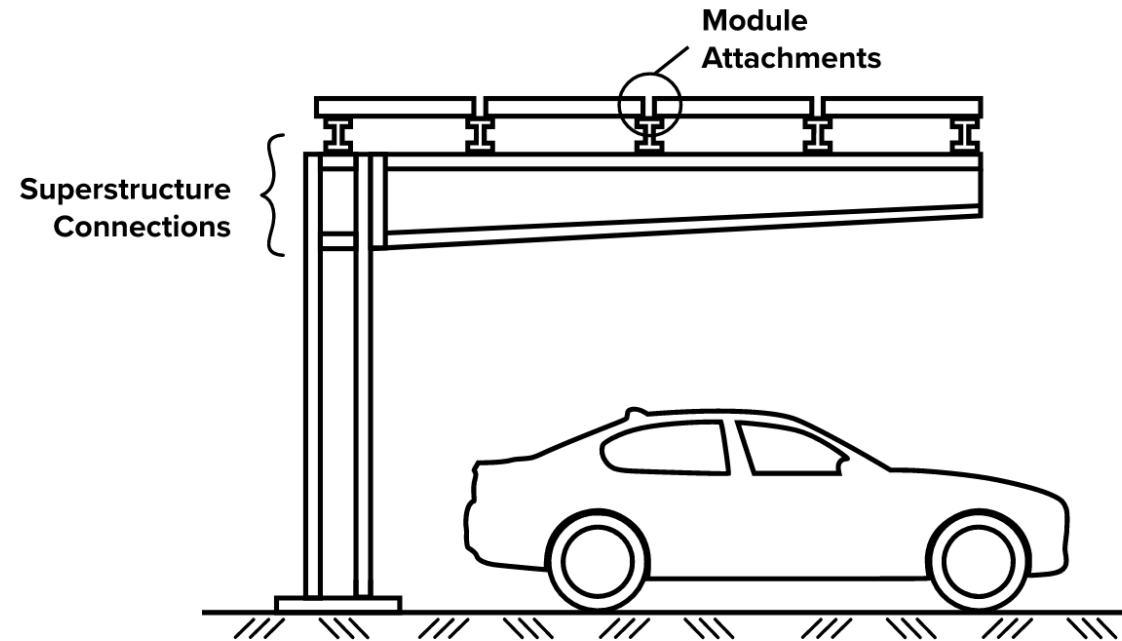

Chapter 4: Structural Design

4.11.2 Bolted Connections

- Calibrate wrenches daily
- Protect fasteners in the field before installation
- Lubricate fasteners as needed
- Design for all loads
 - Static
 - Dynamic

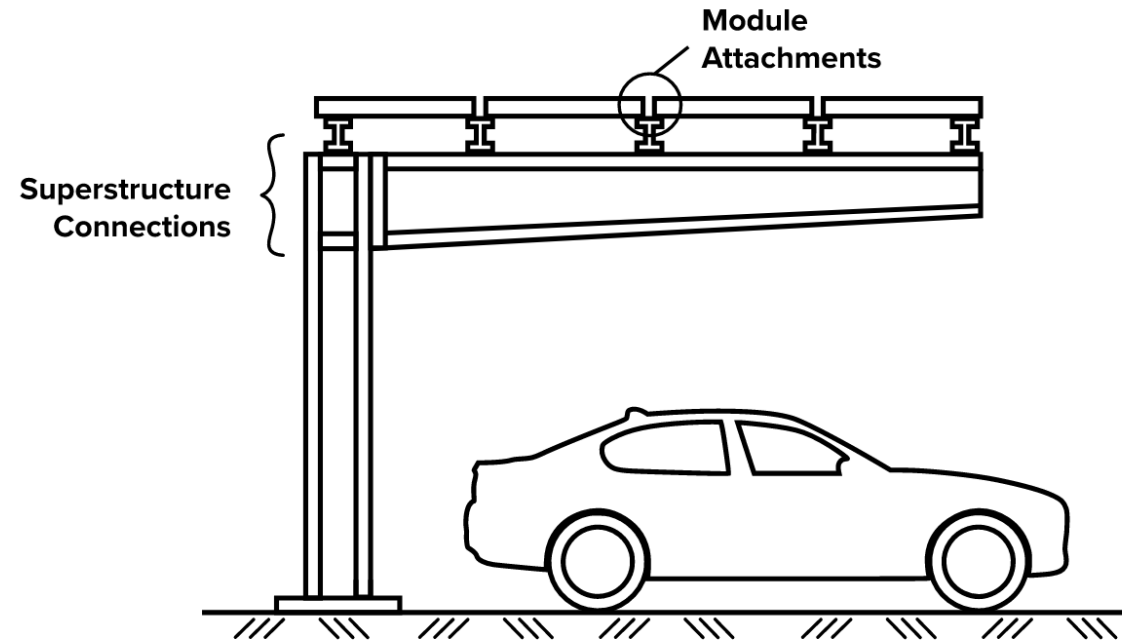

Chapter 4: Structural Design

4.11.2 Bolted Connections

- "Traditional Structural Connections"
 - Diameter and material *within* limits of AISC 360 and RCSC.
- "Alternative Structural Connections"
 - Diameter and/or material *outside* the limits of AISC 360 and RCSC.

*RCSC = Research Council on Structural Connections

Specification for Structural Joints Using High-Strength Bolts

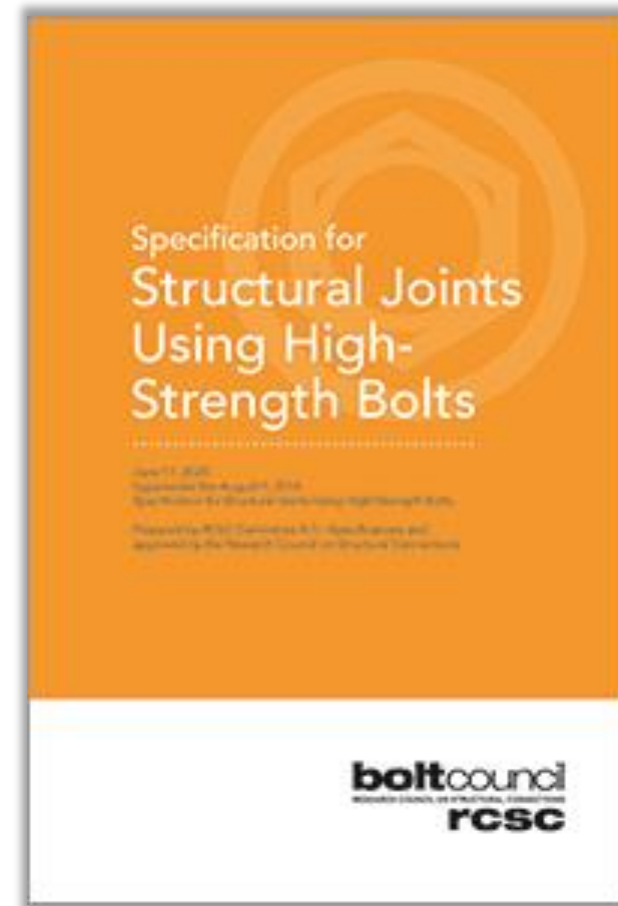

Chapter 4: Structural Design

4.11.2 Bolted Connections

- "Traditional Structural Connections"
 - Diameter and material *within* limits of AISC 360 and RCSC.
- "Alternative Structural Connections"
 - Diameter and/or material *outside* the limits of AISC 360 and RCSC.
- Solar Energy Technologies Office (SETO) funding a Study.
- Need more research!

Table XXX: Module 'Through Bolted' Joint Fastener Standards and Specifications (Imperial)

	External Threads: Bolt, Cap Screw, and Flange Screw		Internal Threads: Trimmed and Flange Nut	Mating Washers
Basic Geometry	ASME B18.2.1		ASME B18.2.2	ASME B18.21.1
Thread Geometry and Gaging	ASME B1.1		ASME B1.1	–
	Min Tensile Strength (ksi)	Specification	Specification of Mating Nut	Specification of Mating Washer
Stainless Steel	60	ASTM F593C	ASTM F594C	AISI 304
		ASTM F593 G	ASTM F594G	AISI 316
Low Carbon Steel	60	SAE J429 Grade 2 ASTM A307A	SAE J995 Grade 2	ASTM F436
Medium Carbon or Alloy Steel	120	SAE J429 Grade 5 ASTM A449 ASTM A354 Grade BC	SAE J995 Grade 5	ASTM F436
Alloy Steel	150	SAE J429 Grade 8 ASTM A354 Grade BD	SAE J995 Grade 8	ASTM F436

Chapter 5: Foundation Design

5.3 Geotechnical Investigations

- Frequency of Testing
 - Number of soil borings
 - Number of test pits
 - Pile Pull Tests
 - Soil Field Tests
- Promote *uniform distribution* of testing throughout the site.

Table XXX: Typical Minimum Frequencies of Geotechnical Field Tests

Test Method	Preliminary Foundation Design	Final Foundation Design
Soil Borings	1 per ■ acres	1 per ■ acres
Test Pits	<i>Depending on expected subsurface conditions and Geotechnical EOR's Recommendation</i>	
Pile Pull Tests	1 test per ■ acres	1 test per ■ acres
Field Electrical Resistivity	1 per ■ acres	1 per ■ acres
Field Thermal Resistivity (RHO)	1 per ■ acres	1 per ■ acres

Chapter 5: Foundation Design

5.3 Geotechnical Investigations

- Frequency of Testing
 - Soil laboratory tests
- **Example:**
 - 1 test / 25 acres ~ 1 test / 1,200 ft
 - 1 test / 50 acres ~ 1 test / 1,600 ft
 - 1 test / 100 acres ~ 1 test / 2,000 ft

Table 5.3: Typical Minimum Frequencies of Geotechnical Lab Tests

Test Method	Reference Standard	Preliminary Foundation Design	Final Foundation Design ¹
Grain Size Analysis + No. 200 Sieve Wash	ASTM C136/D422 & D1140	■ per boring	■ per boring
Atterberg Limits (Liquid & Plastic Limits + Plasticity Index)	ASTM D423	■ per boring	■ per boring
Moisture Content	ASTM D4318	■ per boring	■ per boring
Density of Undisturbed Ring Sample	ASTM D2216	■ per boring	■ per boring
Moisture-Density Relationship (Standard Proctor)	ASTM D2937	■ per boring	■ per boring
Direct Shear (Saturated or Remolded)	ASTM D698	1 per ■ acres	1 per ■ acres
One-Dimensional Consolidation (No time rate curves)	ASTM D3080		
One-Dimensional Swell/Hydrocompression Test	ASTM D2435		
Resistance R-Value	ASTM D4546	1 every ■ borings	1 every ■ borings
pH	ASTM D2844		
Resistivity	ASTM G51 ASTM D4972 ASTM D1293		
Water-Soluble Sulfates Content	ASTM G187		
Chlorides Content	ASTM D4327 ASTM C1580 EPA 9056 ASTM D516		
Sulfide Content	ASTM D512 ASTM D4327 EPA 9056A AASHTO T 291-94		
Oxidation-Reduction Potential	AWWA 4500-S-D ASTM D4658 SM 4500-S2-D		
Salinity	ASTM G200 ASTM D1498		
	AWWA 2520-B		

Chapter 5: Foundation Design

5.3 Geotechnical Investigations

- Uniform distribution of field tests

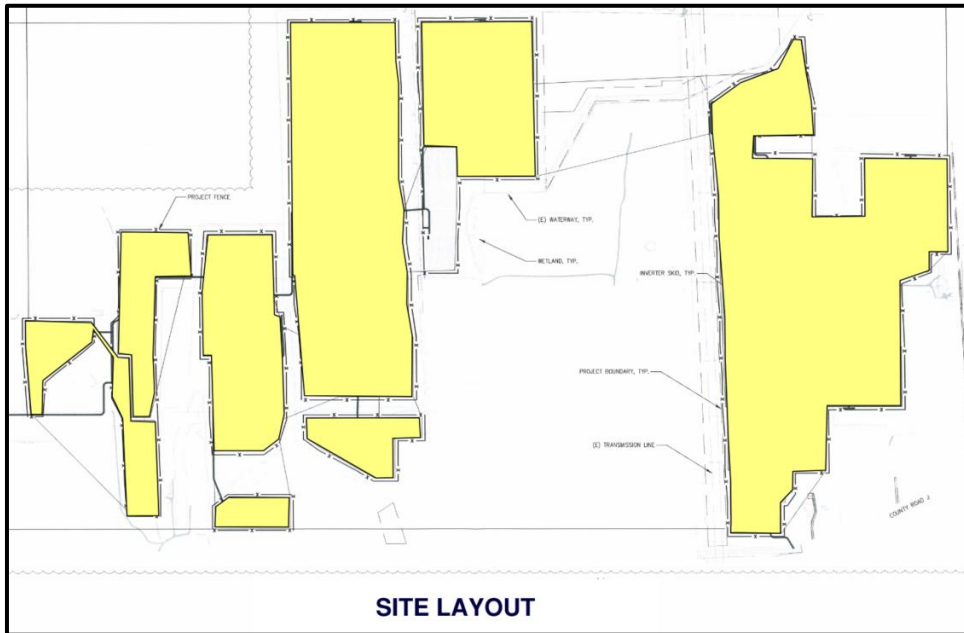

“Method of Circles” (One of MANY methods)

- Place adjacent circles over site layout to locate test locations.
- N = number of acres per test
- Circle OD = $\frac{400N}{\sqrt{N\pi}}$
- Example:
 - $N = 25$ acres; OD = 1,128 ft \sim 1,200 ft
 - $N = 100$ acres; OD = 2,257 ft \sim 2,300 ft

Chapter 5: Foundation Design

5.3 Geotechnical Investigations

- Uniform distribution of field tests

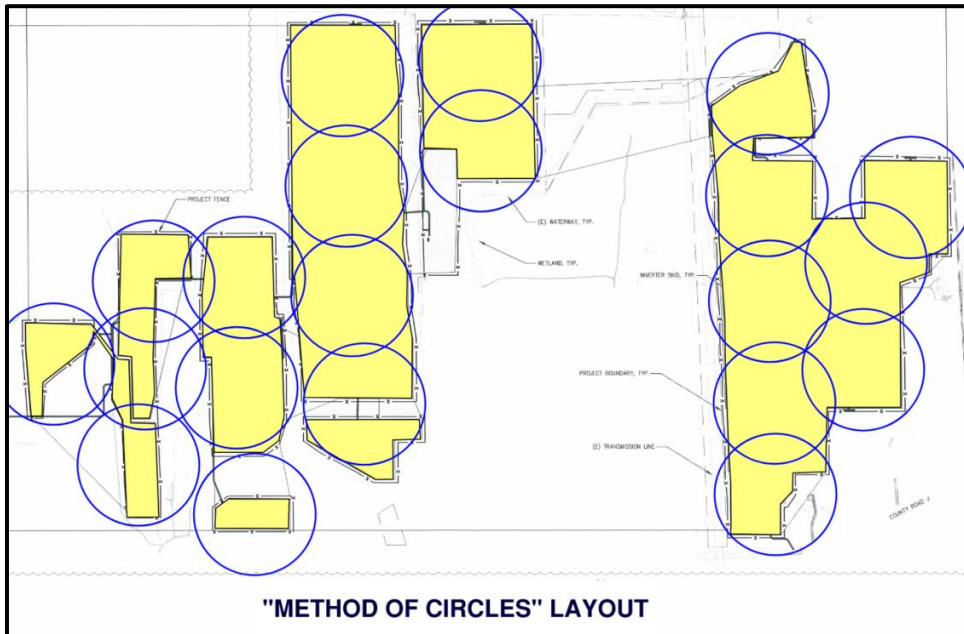

"Method of Circles" (One of MANY methods)

- Place adjacent circles over site layout to locate test locations.
- N = number of acres per test
- Circle OD = $\frac{400N}{\sqrt{N\pi}}$
- Example:
 - $N = 25$ acres; OD = 1,128 ft \sim 1,200 ft
 - $N = 100$ acres; OD = 2,257 ft \sim 2,300 ft

Chapter 5: Foundation Design

5.3 Geotechnical Investigations

- Uniform distribution of field tests

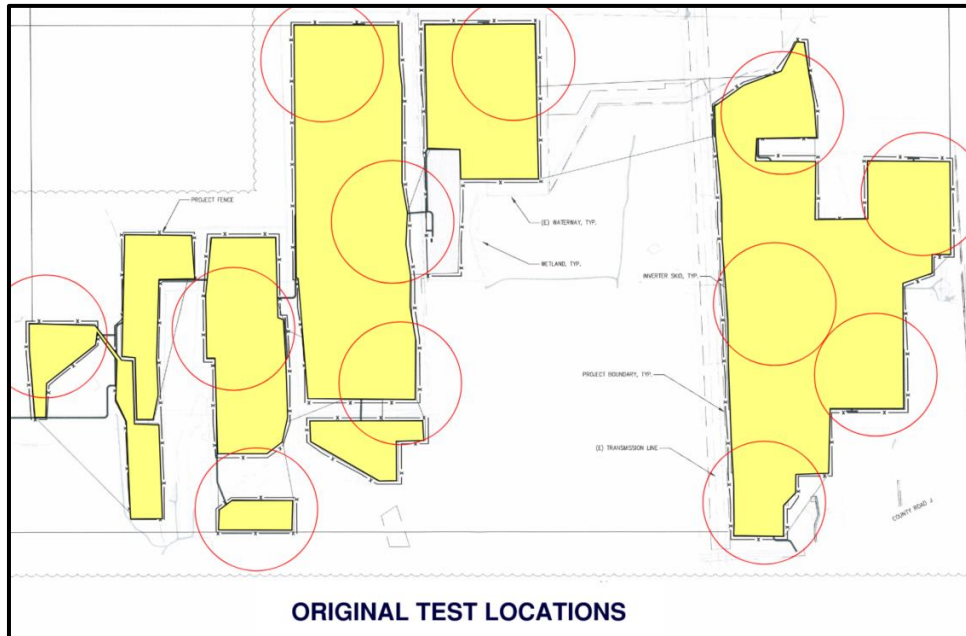

“Method of Circles” (One of MANY methods)

- Place adjacent circles over site layout to locate test locations.
- N = number of acres per test
- Circle OD = $\frac{400N}{\sqrt{N\pi}}$
- Example:
 - $N = 25$ acres; OD = 1,128 ft \sim 1,200 ft
 - $N = 100$ acres; OD = 2,257 ft \sim 2,300 ft

Chapter 5: Foundation Design

5.3 Geotechnical Investigations

- Uniform distribution of field tests

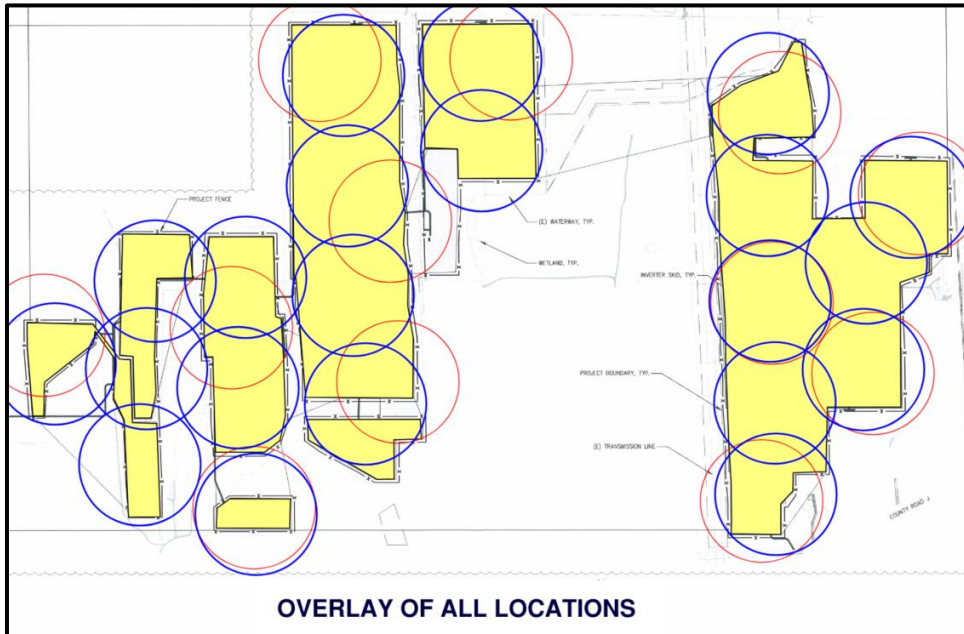

“Method of Circles” (One of MANY methods)

- Place adjacent circles over site layout to locate test locations.
- N = number of acres per test
- Circle OD = $\frac{400N}{\sqrt{N\pi}}$
- Example:
 - $N = 25$ acres; OD = 1,128 ft ~1,200 ft
 - $N = 100$ acres; OD = 2,257 ft ~ 2,300 ft

Chapter 5: Foundation Design

5.5.4 Built-up Piles

- Plate steel
 - SMAW, GMAW, FCAW, SAW
- Coil steel
 - Electric Resistance Forge Welding (ERFW)

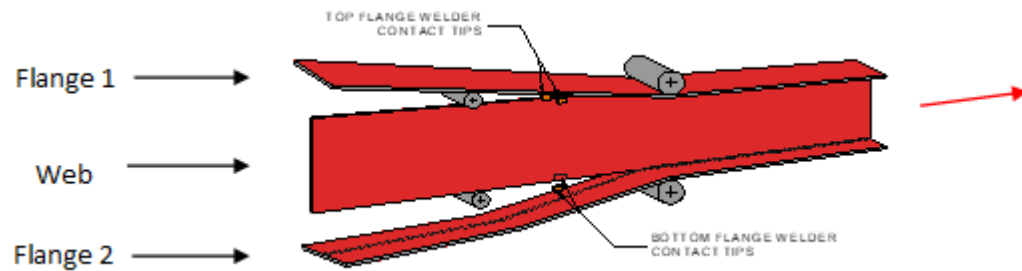

(Figure courtesy of PACO Steel)

Table **xxxx**: Built-up Steel Specifications

Welding Process	ERFW	SMAW, GMAW, FCAW, SAW
Weld Quality Control	ASTM A769	AWS D1.1
Fabrication Tolerances	ASTM A6	ASTM A6
Material Composition	ASTM A769 or ASTM A1011	ASTM A36 or ASTM A572
Material Strength	ASTM A769 or ASTM A1011	ASTM A36 or ASTM A572

Chapter 5: Foundation Design

5.6.1 Driven Steel Piles

5.6.3 Drilled Concrete Piers



H-Pile / Wide Flange

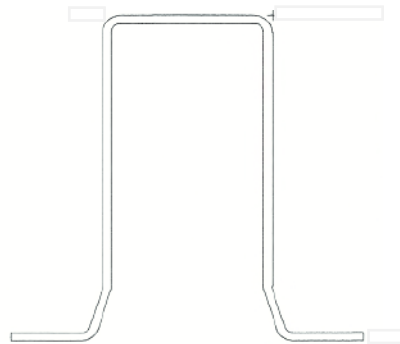

Proprietary Shapes

5.6.4 Helical Anchors

5.6.5 Ground Screws

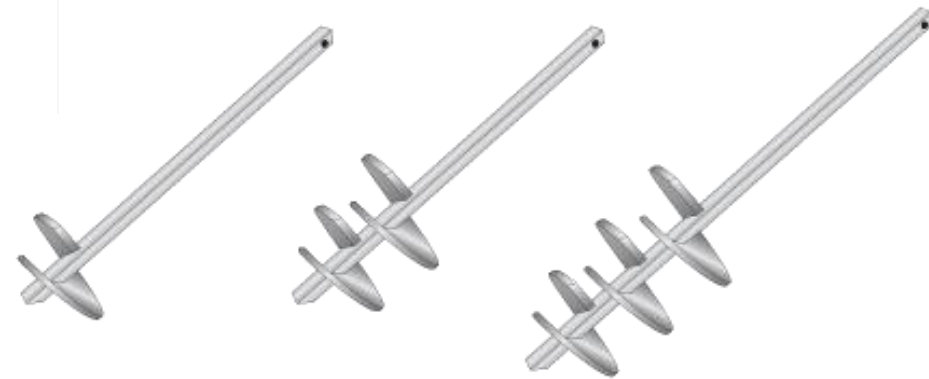

Helical Piers



Ground Screws

Chapter 6: Construction Quality Control

Inspections & Testing

- Guidance on field inspections
- Production pile testing
 - Test % of piles; not all piles
 - Goal = verify soils meet the design strengths the Geotechnical EOR recommended (based on the limited field tests).
- Guidance on pile remediation



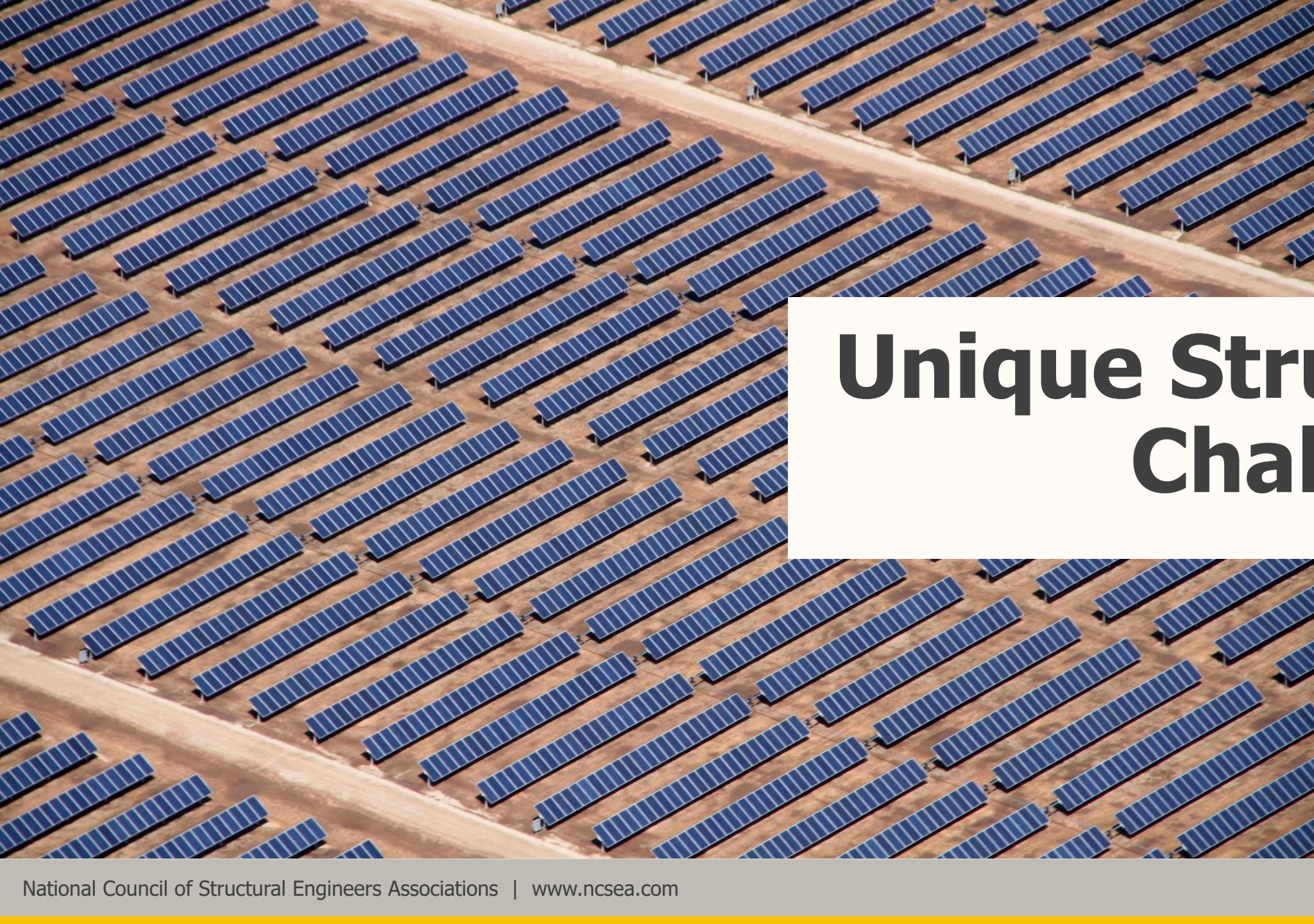

Unique Structural Challenges



150 MWac (1,610 acres) Utility Scale PV Facility

Pile Design w/ Corrosion

- ASTM A123
 - Table 1 – Average coating thickness vs steel thickness
 - Table 2 – Coating thickness
- 1 mil = 1/1,000 inch
- mpy = mils per year
- 2 types of corrosion loss
 - Galvanization (zinc) loss
 - Steel loss

- **Example:**
 - Galvanization thickness = 3.9 mils
 - Zinc loss (per side) = 1.7 mpy
 - Steel loss (per side) = 2.8 mpy
 - BOS Design life = 30 years
- Zinc will last = $3.9 / 1.7 = 2.3$ years
- Steel to last = $30 - 2.3 = 27.7$ years
- Corrosion allowance (per side):
 $27.7 \text{ yrs} \times 2.8 \text{ mpy} = 77.6 \text{ mils}$
 $= 0.078 \text{ inches}$

Pile Design w/ Corrosion

Including the k-area fillet radii allows for ~2% more flexural strength vs ignoring the radius.

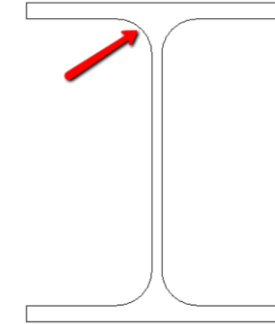

Fillet Radius $r = K_{des} - t_f$

Area $A = 2t_f b_f + (d - 2t_f)t_w + r^2(4 - \pi)$

X-X Axis $I_x = \frac{1}{12} [b_f \times d^3 - (b_f - t_w) \times (d - 2 \times t_f)^3] + 0.03r^4 + 0.2146(d - 2t_f - 0.4468r)^2 r^2$

$$Z_x = 2(b_f t_f) \left[\frac{d}{2} - \frac{t_f}{2} \right] + t_w \left(\frac{d}{2} - t_f \right)^2 + r^2(4 - \pi) \left(\frac{d}{2} - t_f - 0.2234r \right)$$

Y-Y Axis $I_y = \frac{1}{12} [2t_f b_f^3 + (d - 2t_f)t_w^3] + 0.03r^4 + 0.2146 \times (t_w + 0.4468r)^2 r^2$

$$Z_y = \frac{t_f \times b_f^2}{2} + \frac{t_w^2(d - 2t_f)}{4} + r^2(4 - \pi) \left(\frac{t_w}{2} + 0.2234r \right)$$

Built-up Piles

Hot Rolled Steel

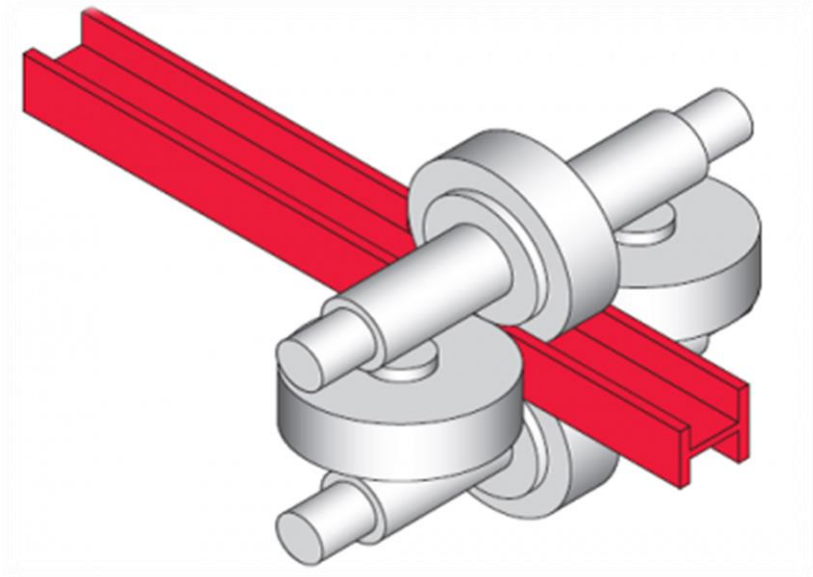

<https://www.manufacturingguide.com/en/hot-rolling-sheets>

Coil Steel

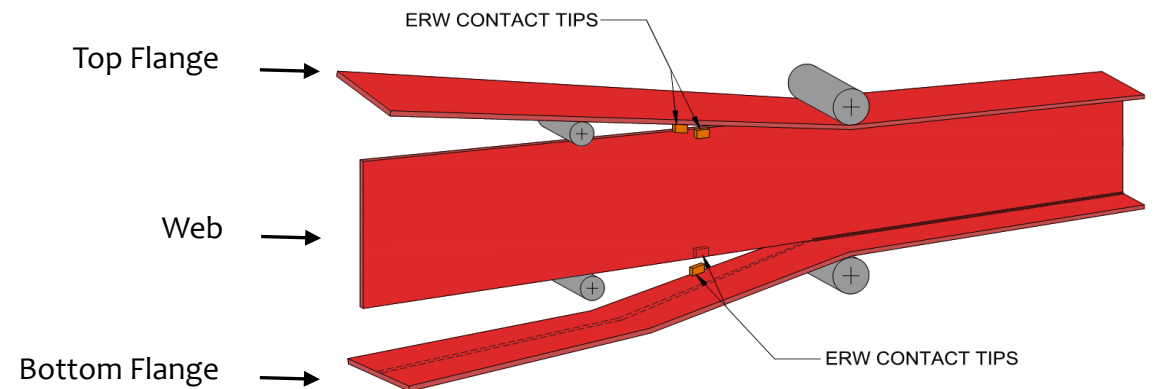

(Figure courtesy of PACO Steel)

Built-up Piles

Steel Construction Manual, 16th Ed.

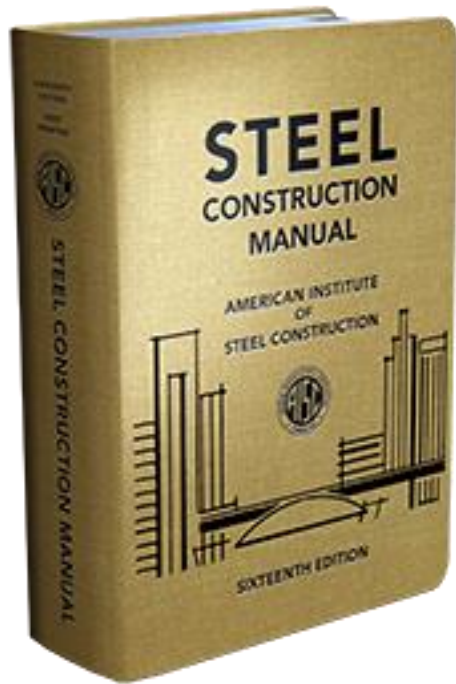

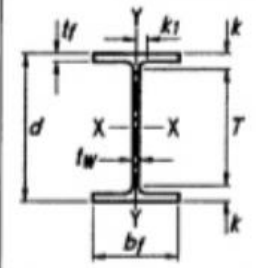

**Table 1-1 (continued)
W-Shapes
Dimensions**

Shape	Area, A in. ²	Depth, d in.	Web		Flange		Distance								
			Thickness, t _w in.	t _w / 2 in.	Width, b _f in.	Thickness, t _f in.	k		k ₁ in.	T in.	Work- able Gage in.				
							k _{des} in.	k _{det} in.							
W6×25	7.34	6.38	6 ³ / ₈	0.320	5 ¹ / ₁₆	3 ¹ / ₁₆	6.08	6 ¹ / ₈	0.455	7 ¹ / ₁₆	0.705	1 ⁵ / ₁₆	9 ¹ / ₁₆	4 ¹ / ₂	3 ¹ / ₂
×20	5.87	6.20	6 ¹ / ₄	0.260	1 ¹ / ₄	1 ¹ / ₈	6.02	6	0.365	3 ³ / ₈	0.615	7 ³ / ₈	9 ¹ / ₁₆	↓	↓
×15 ^f	4.43	5.99	6	0.230	1 ¹ / ₄	1 ¹ / ₈	5.99	6	0.260	1 ¹ / ₄	0.510	3 ³ / ₄	9 ¹ / ₁₆	↓	↓
W6×16	4.74	6.28	6 ¹ / ₄	0.260	1 ¹ / ₄	1 ¹ / ₈	4.03	4	0.405	3 ³ / ₈	0.655	7 ³ / ₈	9 ¹ / ₁₆	4 ¹ / ₂	2 ¹ / ₄ ^o
×12	3.55	6.03	6	0.230	1 ¹ / ₄	1 ¹ / ₈	4.00	4	0.280	1 ¹ / ₄	0.530	3 ³ / ₄	9 ¹ / ₁₆	↓	↓
×9 ^f	2.68	5.90	5 ⁷ / ₈	0.170	3 ¹ / ₁₆	1 ¹ / ₈	3.94	4	0.215	3 ¹ / ₁₆	0.465	1 ¹ / ₁₆	1 ¹ / ₂	↓	↓
×8 5 ^f	2.52	5.83	5 ⁷ / ₈	0.170	3 ¹ / ₁₆	1 ¹ / ₈	3.94	4	0.195	3 ¹ / ₁₆	0.445	1 ¹ / ₁₆	1 ¹ / ₂	↓	↓

[Steel Construction Manual, 16th Ed. \(Print\) | American Institute of Steel Construction \(aisc.org\)](#)

Built-up Piles

Steel Construction Manual, 16th Ed.

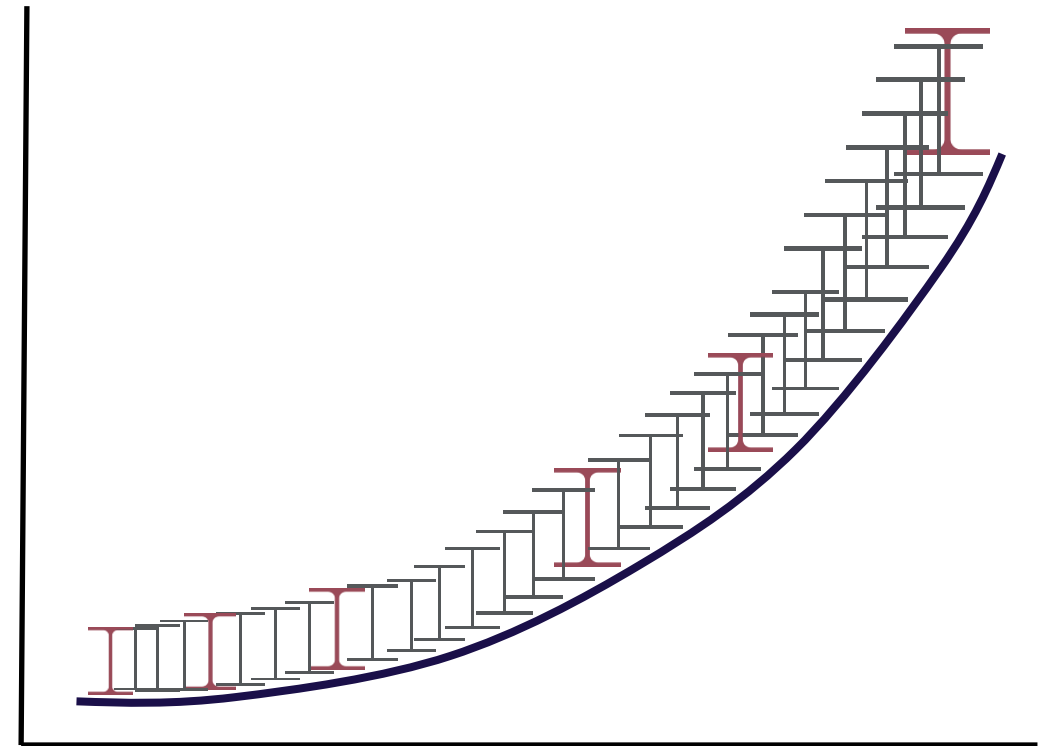
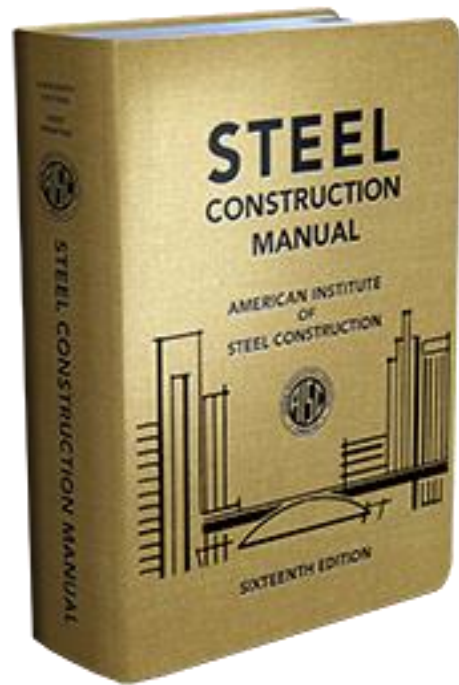

[Steel Construction Manual, 16th Ed. \(Print\) | American Institute of Steel Construction \(aisc.org\)](#)

Built-up Piles

Benefits:

- Allows the market to reduce:
 - Cost
 - Lead times
- Averages 10% to 25% steel reduction
- Less steel -> fewer trucks & lower zinc cost

Allows for unique pile solutions



SYMMETRICAL

WEB OFFSET

DIFFERENT
FLANGE
WIDTHS

DIFFERENT
FLANGE
THICKNESS



Structural Reliability

ASCE 7 Prescriptive Methods

Table 1.3-1. Target Reliability and Associated Reliability Indices

Basis	Risk Category			
	I	II	III	IV
Failure that is not sudden and does not lead to widespread progression of damage	$P_F = 1.25 \times 10^{-4}$ per year $\beta = 2.5$	$P_F = 3.0 \times 10^{-5}$ per year $\beta = 3.0$	$P_F = 1.25 \times 10^{-5}$ per year $\beta = 3.25$	$P_F = 5.0 \times 10^{-6}$ per year $\beta = 3.5$
Failure that is either sudden or leads to widespread progression of damage	$P_F = 3.0 \times 10^{-5}$ per year $\beta = 3.0$	$P_F = 5.0 \times 10^{-6}$ per year $\beta = 3.5$	$P_F = 2.0 \times 10^{-6}$ per year $\beta = 3.75$	$P_F = 7.0 \times 10^{-7}$ per year $\beta = 4.0$
Failure that is sudden and results in widespread progression of damage	$P_F = 5.0 \times 10^{-6}$ per year $\beta = 3.5$	$P_F = 7.0 \times 10^{-7}$ per year $\beta = 4.0$	$P_F = 2.5 \times 10^{-7}$ per year $\beta = 4.25$	$P_F = 1.0 \times 10^{-7}$ per year $\beta = 4.5$

Structural Reliability

Use LRFD... *where possible*

- AISC 360
 - Racking
 - Connections*
 - Pile Foundations
- ACI 318
 - Foundations
- AASHTO (One option...for now)
 - Soil Strength w/ or w/o Testing

AASHTO Table 10.5.5.2.3-1 Resistance Factors for Driven Piles

	Condition/Resistance Determination Method	Resistance Factor	
Nominal Bearing Resistance of Single Pile—Dynamic Analysis and Static Load Test Methods, ϕ_{dyn}	Driving criteria established by successful static load test of at least one pile per site condition and dynamic testing* of at least two piles per site condition, but no less than 2% of the production piles	0.80	
	Driving criteria established by successful static load test of at least one pile per site condition without dynamic testing	0.75	
	Driving criteria established by dynamic testing* conducted on 100% of production piles	0.75	
	Driving criteria established by dynamic testing*, quality control by dynamic testing* of at least two piles per site condition, but no less than 2% of the production piles	0.65	
	Wave equation analysis, without pile dynamic measurements or load test but with field confirmation of hammer performance	0.50	
	FHWA-modified Gates dynamic pile formula (End of Drive condition only)	0.40	
	Engineering News (as defined in Article 10.7.3.8.5) dynamic pile formula (End of Drive condition only)	0.10	
Nominal Bearing Resistance of Single Pile—Static Analysis Methods, ϕ_{stat}	Side Resistance and End Bearing: Clay and Mixed Soils α -method (Tomlinson, 1987; Skempton, 1951) β -method (Esrig & Kirby, 1979; Skempton, 1951) λ -method (Vijayvergiya & Focht, 1972; Skempton, 1951)	0.35 0.25 0.40	
	Side Resistance and End Bearing: Sand Nordlund/Thurman Method (Hannigan et al., 2005) SPT-method (Meyerhof)	0.45 0.30	
	CPT-method (Schmertmann)	0.50	
	End bearing in rock (Canadian Geotech. Society, 1985)	0.45	
	Block Failure, ϕ_{b1}	Clay	0.60
	Uplift Resistance of Single Piles, ϕ_{up}	Nordlund Method α -method β -method λ -method SPT-method CPT-method Static load test Dynamic test with signal matching	0.35 0.25 0.20 0.30 0.25 0.40 0.60 0.50
Group Uplift Resistance, ϕ_{ug}		All soils	0.50
Lateral Geotechnical Resistance of Single Pile or Pile Group		All soils and rock	1.0

Structural Reliability

ASCE 7 Performance Based Design

- ASCE 7 Section 1.3.1.3 and C1.3.1.3
- *An alternative to prescriptive methods that uses project specific engineering to calculate the reliability of a structure.*

(Ref ASCE 7, Ch. 1 for full definition)

- “The lack of performance-based design provisions within a chapter should not be taken as prohibition on the use of performance-based procedures for that specific load or environmental hazard.” ASCE 7, Section C1.3.1.3

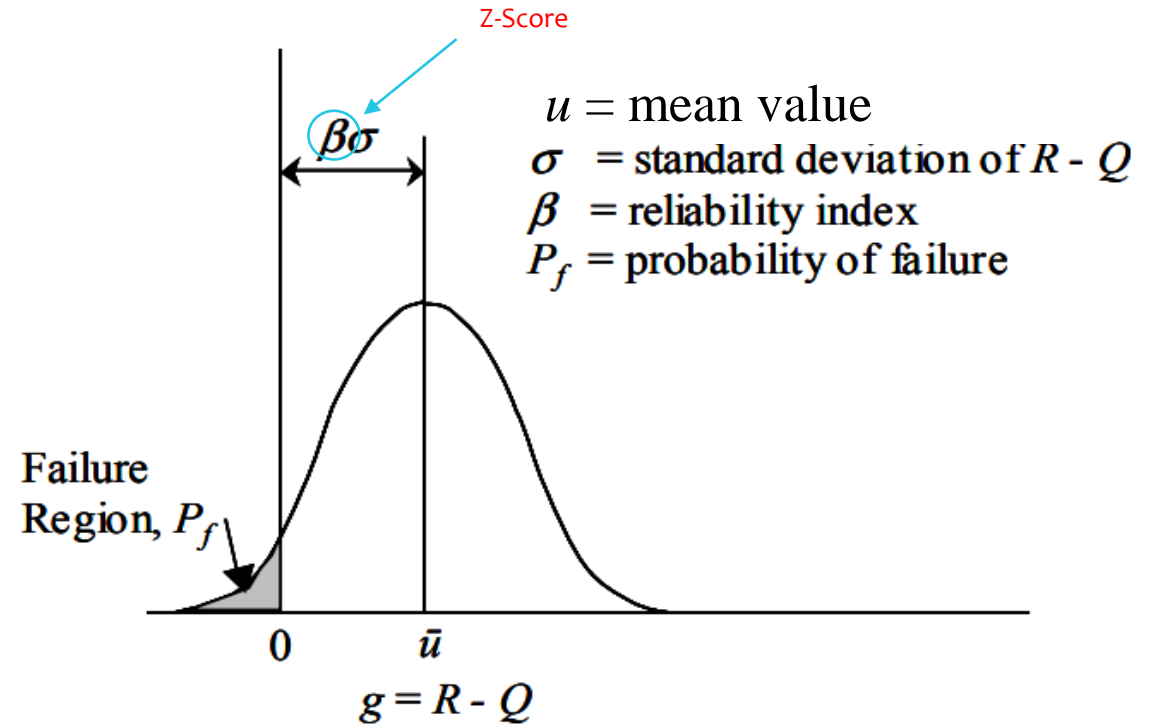

<https://onlinepubs.trb.org/onlinepubs/circulars/ec079.pdf>

Steve Gartner, P.E., M.ASCE

Principal Engineer Renewable Energy, HDR

Chair Solar PV Structures Committee

steven.gartner@hdrinc.com



Questions?